

User Manual

FaceKoisk-H13

Date: January 2021

Doc Version: 2.1

English

Thank you for choosing our product. Please read the instructions carefully before operation. Follow these instructions to ensure that the product is functioning properly. The images shown in this manual are for illustrative purposes only.



For further details, please visit our Company's website www.zkteco.com.

Copyright © 2021 ZKTECO CO., LTD. All rights reserved.

Without the prior written consent of ZKTeco, no portion of this manual can be copied or forwarded in any way or form. All parts of this manual belong to ZKTeco and its subsidiaries (hereinafter the "Company" or "ZKTeco").

Trademark

ZKTeco is a registered trademark of ZKTeco. Other trademarks involved in this manual are owned by their respective owners.

Disclaimer

This manual contains information on the operation and maintenance of the ZKTeco equipment. The copyright in all the documents, drawings, etc. in relation to the ZKTeco supplied equipment vests in and is the property of ZKTeco. The contents hereof should not be used or shared by the receiver with any third party without express written permission of ZKTeco.

The contents of this manual must be read as a whole before starting the operation and maintenance of the supplied equipment. If any of the content(s) of the manual seems unclear or incomplete, please contact ZKTeco before starting the operation and maintenance of the said equipment.

It is an essential pre-requisite for the satisfactory operation and maintenance that the operating and maintenance personnel are fully familiar with the design and that the said personnel have received thorough training in operating and maintaining the machine/unit/equipment. It is further essential for the safe operation of the machine/unit/equipment that personnel has read, understood and followed the safety instructions contained in the manual.

In case of any conflict between terms and conditions of this manual and the contract specifications, drawings, instruction sheets or any other contract-related documents, the contract conditions/documents shall prevail. The contract specific conditions/documents shall apply in priority.

ZKTeco offers no warranty, guarantee or representation regarding the completeness of any information contained in this manual or any of the amendments made thereto. ZKTeco does not extend the warranty of any kind, including, without limitation, any warranty of design, merchantability or fitness for a particular purpose.

ZKTeco does not assume responsibility for any errors or omissions in the information or documents which are referenced by or linked to this manual. The entire risk as to the results and performance obtained from using the information is assumed by the user.

ZKTeco in no event shall be liable to the user or any third party for any incidental, consequential, indirect, special, or exemplary damages, including, without limitation, loss of business, loss of profits, business interruption, loss of business information or any pecuniary loss, arising out of, in connection with, or relating

to the use of the information contained in or referenced by this manual, even if ZKTeco has been advised of the possibility of such damages.

This manual and the information contained therein may include technical, other inaccuracies or typographical errors. ZKTeco periodically changes the information herein which will be incorporated into new additions/amendments to the manual. ZKTeco reserves the right to add, delete, amend or modify the information contained in the manual from time to time in the form of circulars, letters, notes, etc. for better operation and safety of the machine/unit/equipment. The said additions or amendments are meant for improvement /better operations of the machine/unit/equipment and such amendments shall not give any right to claim any compensation or damages under any circumstances.

ZKTeco shall in no way be responsible (i) in case the machine/unit/equipment malfunctions due to any non-compliance of the instructions contained in this manual (ii) in case of operation of the machine/unit/equipment beyond the rate limits (iii) in case of operation of the machine and equipment in conditions different from the prescribed conditions of the manual.

The product will be updated from time to time without prior notice. The latest operation procedures and relevant documents are available on <http://www.zkteco.com>

If there is any issue related to the product, please contact us.

ZKTeco Headquarters

Address ZKTeco Industrial Park, No. 32, Industrial Road,

Tangxia Town, Dongguan, China.

Phone +86 769 - 82109991

Fax +86 755 - 89602394

For business-related queries, please write to us at sales@zkteco.com.

To know more about our global branches, visit www.zkteco.com.

About the Company

ZKTeco is one of the world's largest manufacturer of RFID and Biometric (Fingerprint, Facial, Finger-vein) readers. Product offerings include Access Control readers and panels, Near & Far-range Facial Recognition Cameras, Elevator/floor access controllers, Turnstiles, License Plate Recognition (LPR) gate controllers and Consumer products including battery-operated fingerprint and face-reader Door Locks. Our security solutions are multi-lingual and localized in over 18 different languages. At the ZKTeco state-of-the-art 700,000 square foot ISO9001-certified manufacturing facility, we control manufacturing, product design, component assembly, and logistics/shipping, all under one roof.

The founders of ZKTeco have been determined for independent research and development of biometric verification procedures and the productization of biometric verification SDK, which was initially widely applied in PC security and identity authentication fields. With the continuous enhancement of the development and plenty of market applications, the team has gradually constructed an identity authentication ecosystem and smart security ecosystem, which are based on biometric verification techniques. With years of experience in the industrialization of biometric verifications, ZKTeco was officially established in 2007 and now has been one of the globally leading enterprises in the biometric verification industry owning various patents and being selected as the National High-tech Enterprise for 6 consecutive years. Its products are protected by intellectual property rights.

About the Manual

This manual introduces the operations of FaceKiosk-H13.

All figures displayed are for illustration purposes only. Figures in this manual may not be exactly consistent with the actual products.

Document Conventions

Conventions used in this manual are listed below:

GUI Conventions

For Device	
Convention	Description
< >	Button or key names for devices. For example, press <OK>
[]	Window names, menu items, data table, and field names are inside square brackets. For example, pop up the [New User] window
/	Multi-level menus are separated by forwarding slashes. For example, [File/Create/Folder].

Symbols





Convention	Description
	This implies about the notice or pays attention to, in the manual
	The general information which helps in performing the operations faster
	The information which is significant
	Care taken to avoid danger or mistakes
	The statement or event that warns of something or that serves as a cautionary example.

Table of Contents

1	OVERVIEW	7
1.1	SPECIFICATIONS.....	7
1.2	INSTALLATION SET-UP	8
1.2.1	SAFETY PRECAUTIONS.....	8
1.2.2	INSTALLATION ENVIRONMENT	8
1.2.3	INSTALLATION PROCEDURE	8
1.3	PRODUCT APPEARANCE	12
1.4	PRODUCT INTERFACE.....	14
1.5	DEVICE CONNECTION.....	14
2	HOME SCREEN AND MAIN MENU	16
2.1	MAIN MENU	17
3	VISITOR REGISTRATION PROCESS	19
3.1	VISITOR SIGN IN.....	19
3.1.1	PRIVACY PROTECTION POLICY	19
3.1.2	FACE REGISTRATION	20
3.1.3	DECLARATION OF HEALTH INFORMATION.....	20
3.1.4	VISITOR INFORMATION.....	21
3.1.5	HOST INFORMATION.....	21
3.1.6	VOLUNTEER AUDIT.....	22
3.1.7	COMPLETE REGISTRATION	22
3.2	VISITOR QUERY	23
3.3	VISITOR CHECK-IN	23
3.4	VISITOR CHECK OUT	24
4	USER MANAGEMENT	25
4.1	ADD AN EMPLOYEE.....	26
4.2	DELETE AN EMPLOYEE	29
5	COMMUNICATION SETTINGS	30
5.1	WI-FI SETTINGS.....	30
5.2	ETHERNET SETTINGS	30
5.3	SERVER SETTINGS	31
6	VISITOR PARAMETER	32
6.1	DETECTION MANAGEMENT	33
7	SYSTEM SETTINGS	34
7.1	TIME AND DATE.....	34
7.2	MENU TIMEOUT.....	34
7.3	QR CODE SETTINGS.....	35
8	DATA MANAGEMENT	36

8.1 CLEAR DATA.....36

8.2 BACKUP DATA.....37

8.3 RESTORE DATA.....37

9 USB MANAGEMENT39

9.1 UPLOADING DATA FROM THE USB DRIVE39

10 RECORD SEARCH40

10.1 VISITOR RECORD40

11 ADVERTISEMENT SETTINGS41

12 SYSTEM INFORMATION42

13 ZKBIOSECURITY CONNECTION43

13.1 ADDING A DEVICE.....43

13.2 VISITOR MANAGEMENT.....43

13.2.1 SET THE FACEKIOSK AS AN ENTRY POINT43

13.2.2 HOST SETTINGS.....44

13.2.3 VISIT REASON SETTINGS.....45

13.2.4 RESERVATION AUDIT SETTINGS45

13.2.5 EMAIL NOTIFICATION SETTINGS.....46

13.2.6 INVITATION.....47



13.2.7 VISITOR REGISTRATION QR CODE SETTINGS.....48

13.2.8 DECLARATION OF HEALTH INFORMATION.....49

1 Overview

FaceKiosk-H13 is a multi-purpose smart face recognition device with an Android operating system. It provides the best solution for various enterprise requirements such as Visitor self-service, Conference display, e-learning classes, and so on. The installation is very simple, and its compact structure makes it best-fit in any working environment.

1.1 Specifications

FaceKiosk-H13			
Feature	FaceKiosk-H13A	FaceKiosk-H13C	FaceKiosk-H13C [TD]
Visitor Records Capacity	100000	100000	100000
Facial Templates Capacity	10000	10000	10000
Waterproof IP Rating	IP65	-	-
Dimensions	323*268*25mm (L*W*H)	354*50*1420mm (L*W*H)	354*50*1420mm (L*W*H)
Hardware Modules	IC Card, Fingerprint Scanner, Ticket Printer, QR Code Scanner	IC Card, Fingerprint Scanner, Ticket Printer, QR Code Scanner	IC Card, Fingerprint Scanner, Ticket Printer, QR Code Scanner, Temperature Detection module
CPU	Quad-core A17 1.8GH (ZKTeco boosted)		
Operating Frequency	1.8GHz		
Operating System	Android 5.1.1		
RAM	2GB DDR3		
ROM	16GB		
Ports	1*RJ45, TF card slot, 1*HDMI, RS232/485		
Images			

1.2 Installation Set-up

1.2.1 Safety Precautions

- Keep the device away from water or dampness. Prevent the entry of water or moisture into the kiosk's chassis.
- Make sure the device room is well ventilated and keep the kiosk's ventilation vents clear of obstruction.
- Make sure that the operating voltage is the same as labeled on the kiosk.
- Do not open the chassis when the kiosk is operating or when electrical hazards are present to avoid electrical shocks.

1.2.2 Installation Environment

The device shall be installed indoors, and adequate clearance shall be reserved for heat dissipation at the inlet/exhaust air vents.

Feature	Description
Operating Temperature	0°C to 50°C
Operating Humidity	<90% RH
Storage Humidity	20% to 90% RH

Body Temperature Detection Specifications (FaceKiosk-H13C [TD] only)

Feature	Description
Detection Aspects	Mask Detection Body Temperature Detection
Temperature Measurement Distance	30 to 50cm (1 to 1.64ft)
Temperature Measurement Accuracy	±0.3°C (±0.56°F)
Temperature Measurement Range	34°C to 45°C (93.2°F to 113°F)

1.2.3 Installation Procedure

Please make sure that the Kiosk is installed as per the installation instructions. You should contact the agent for permission if you would like to open the chassis. Otherwise, you will bear any consequences of your actions.

Wall Mounted Device – H13A:

Before installation, connect the wire to the device and pass it on through the lower opening of the device.

1. Align the back plate with respect to the screw holes on the back of the device.

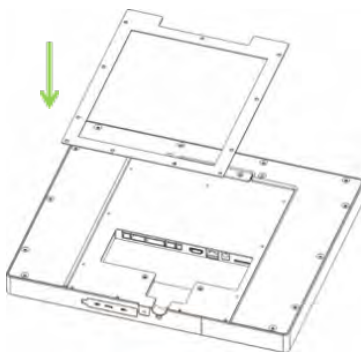

2. Secure the plate with screws (11 pcs) to the back of the device

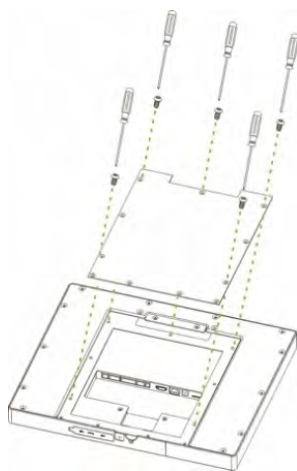

3. Ensure that the rear panel is mounted on the wall at a desirable height. Drill the holes on the wall and fix the rear panel with screws.

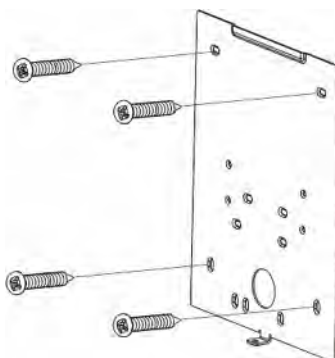

4. Affix the device to the rear panel.

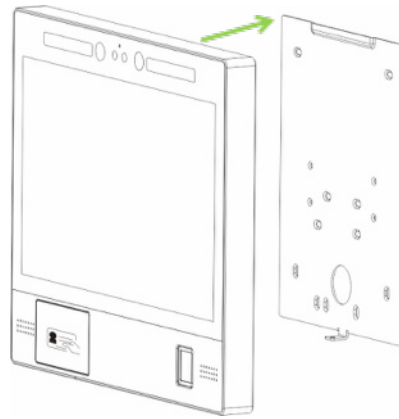

- 5. Secure the device and the rear panel with a screw at the bottom.

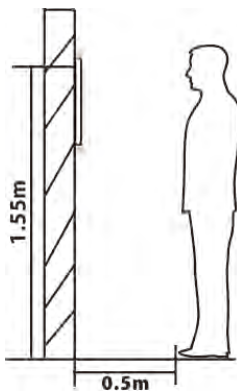
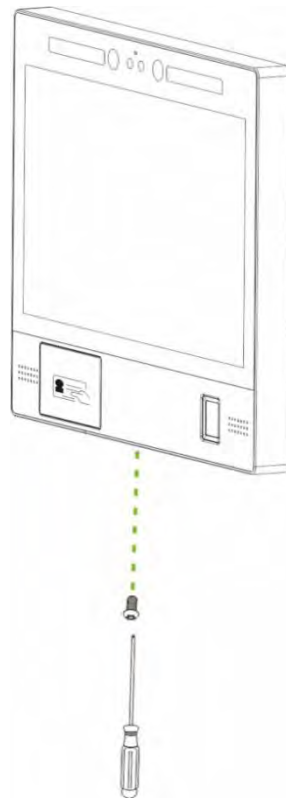

The recommended distance from the camera to the ground is 155cm. The recommended distance from the person to the device is 50cm (applicable height range is 150cm to 180cm). If the person's height is not within this range, it is possible to move the front and rear positions accordingly.

Floor Mounted Device-H13C:

1. Open the device box, remove the Device and the base. Insert the device into the corresponding base slot.

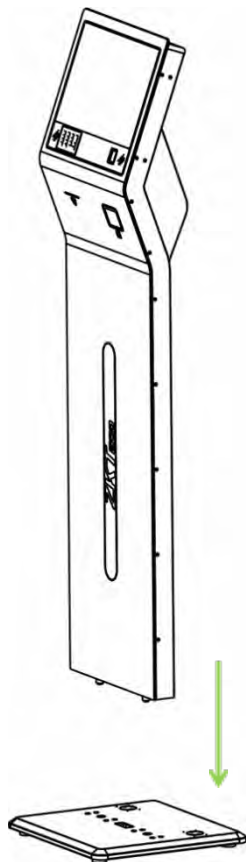

2. Gently recline the device horizontally and secure the device to the base with the screws (8 pcs) from the bottom of the base.

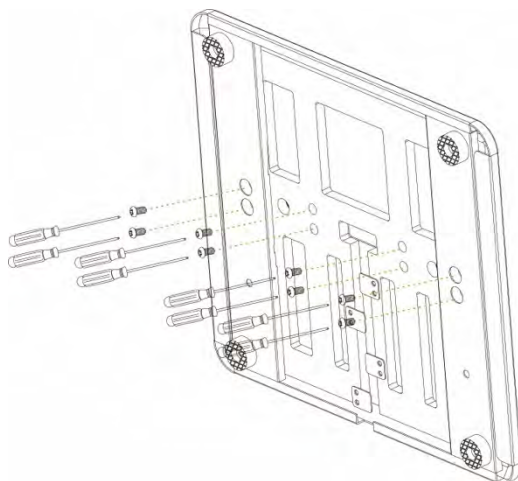

1.3 Product Appearance

FaceKiosk H13 A

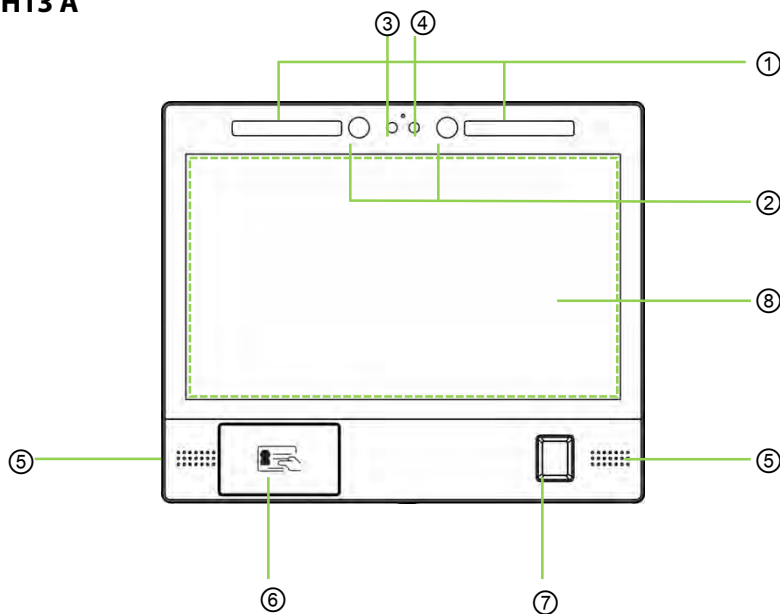

①	LED Fill Light	⑤	Speakers
②	Near-Infrared Fill Light	⑥	IC Card Module
③	Visible Light Camera	⑦	QR Code Scanner
④	Near-Infrared Camera	⑧	13.3-inch High-definition Capacitive Touch Screen

FaceKiosk H13C

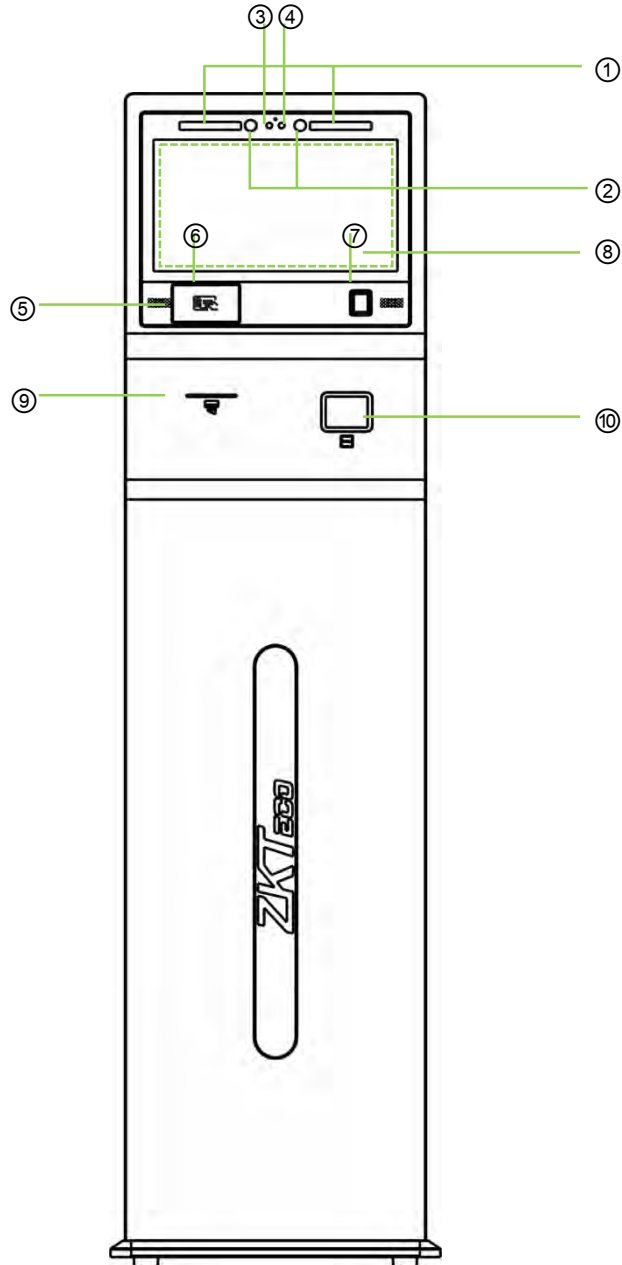

①	LED Fill Light	⑥	MiFare Card Module
②	Near-Infrared Fill Light	⑦	Fingerprint Reader
③	Visible Light Camera	⑧	13.3-inch High-definition Capacitive Touch Screen
④	Near-Infrared Camera	⑨	Ticket Printer
⑤	Speakers	⑩	QR Code Scanner

1.4 Product Interface

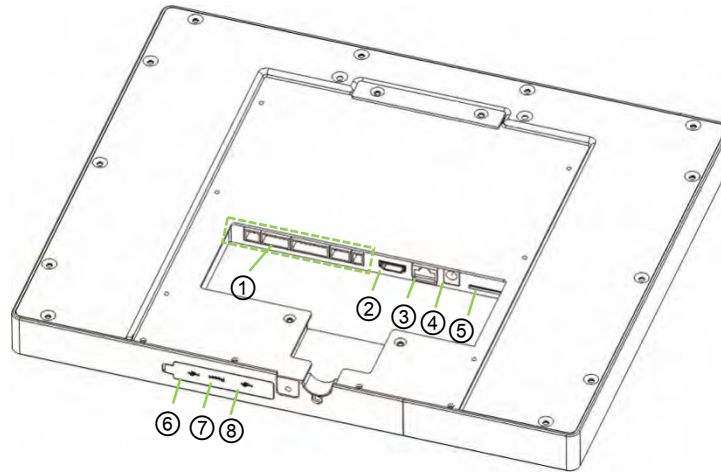

①	Connecting Terminal	⑤	SIM Card Slot
②	HDMI Port	⑥	USB Port
③	Network Port	⑦	Reset Button
④	12V-3A Power Interface	⑧	USB Port

1.5 Device Connection

On the back of the device, there are five rows of slots, which are J1, J2, J3, J4, and J5 from left to right. J1 is connected to the alarm, J2 is connected to the door, J3 is connected to the external device, J4 is connected to the Wiegand input, and the J5 is the power output port reserved for a Printer.

J1	J2	J3	J4	J5
NO	SEN	485B	12V	GND
COM	GND	485A	GND	INWD0
NC	BUT	GND	INWD1	12V
	NO1	TXD		
	COM1	RXD		
	NC1	WD0		
		WD1		
		GND		

Diagram

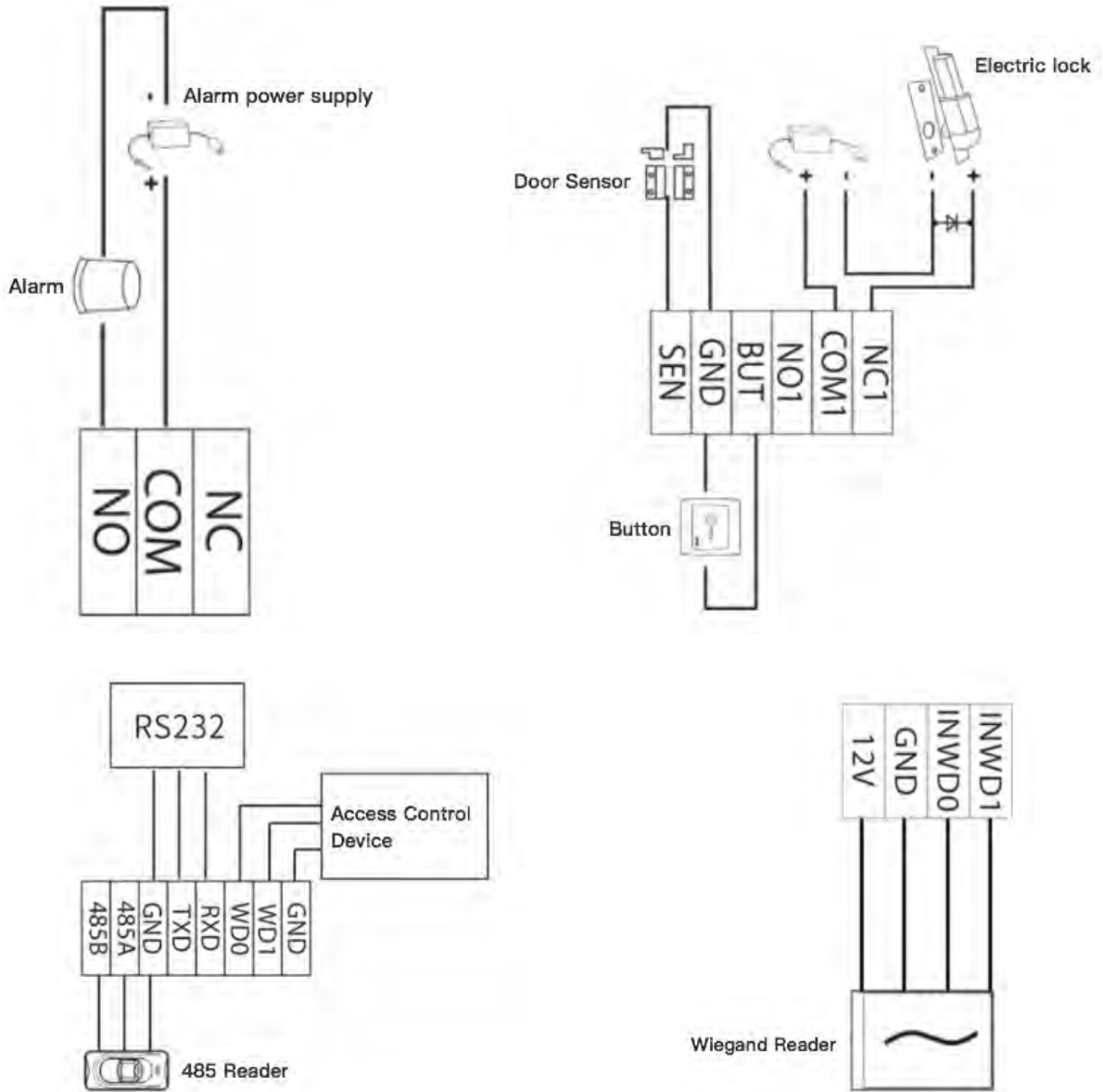

2 Home Screen and Main Menu

The home screen is divided into the following sections:

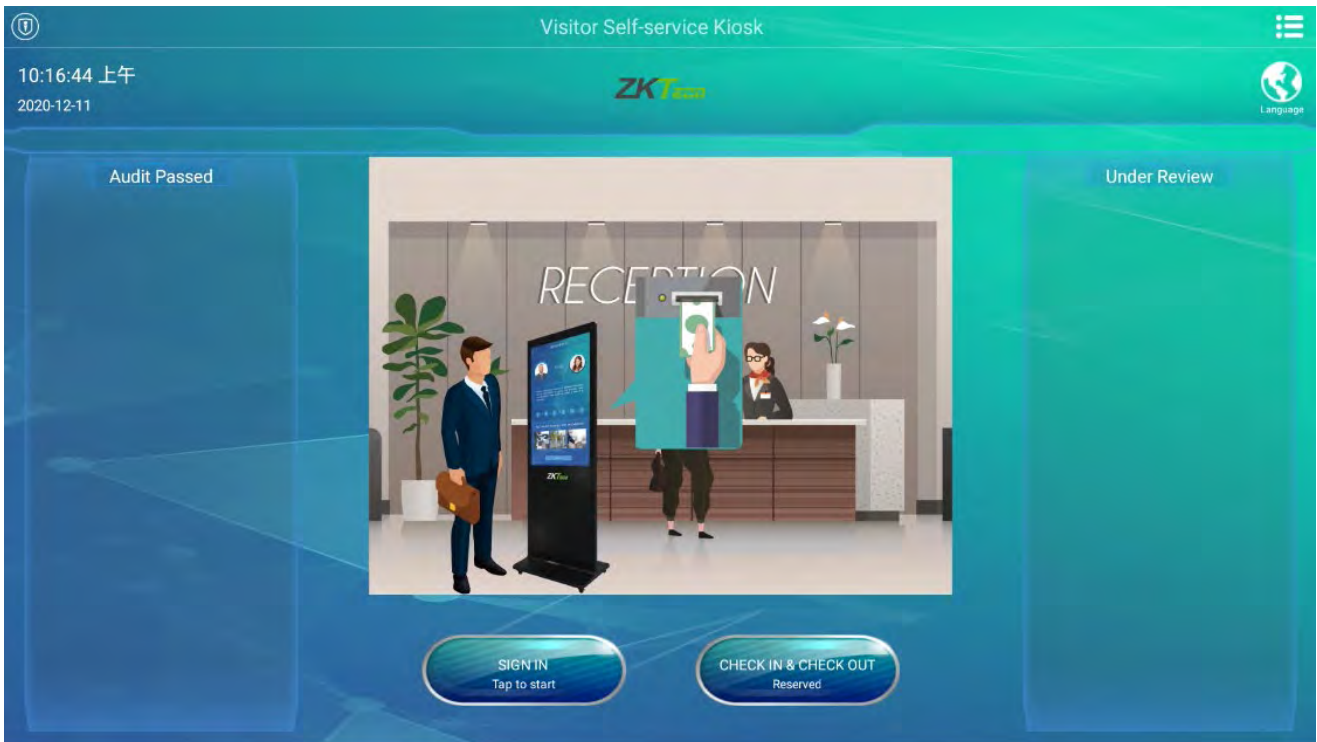

Title bar: Displays the Name of the device, Software status, and the Main menu button.

Audit Passed: Displays the approved visitor details.

Under Review: Displays the name of the visitor being audited.

Description of Icons in Home screen:

Main Menu: Tap on  to open the Main menu.

Language: Tap on  to change the System language. The device supports English, Russian, Latin Spanish, and Thai.

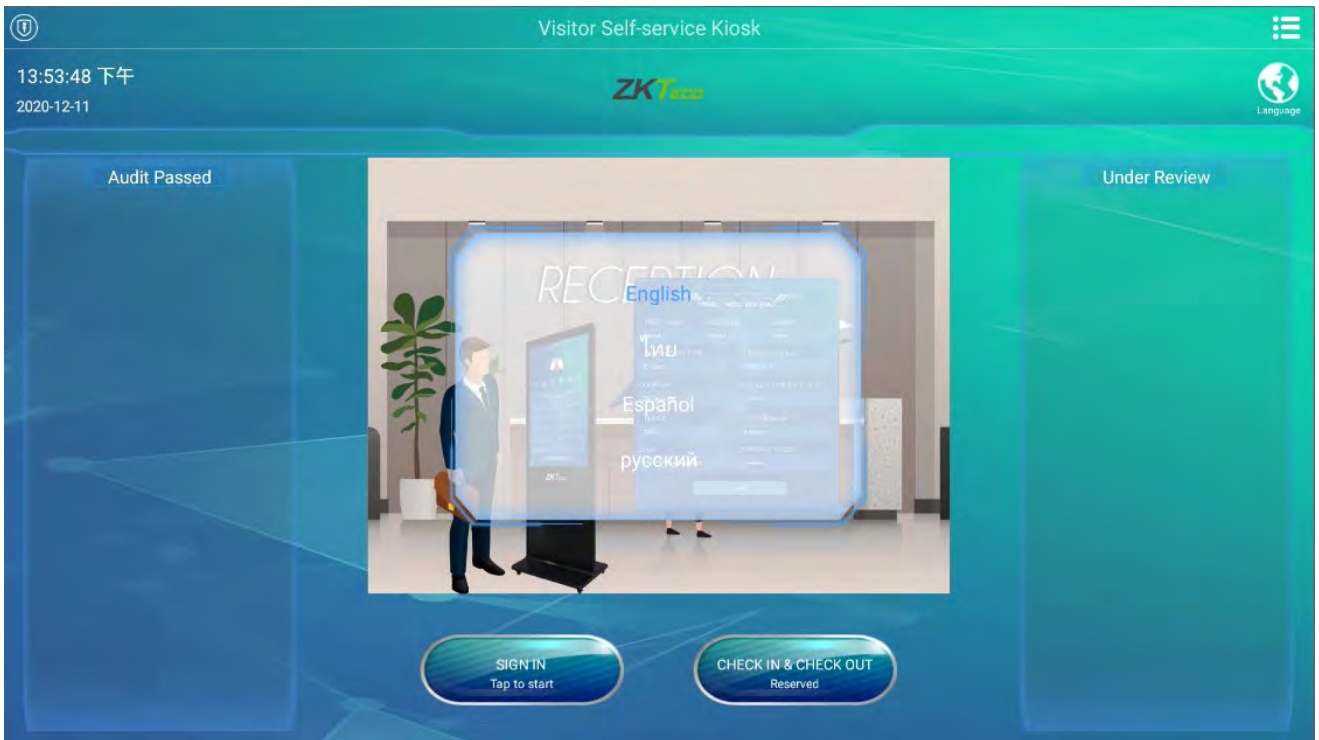

2.1 Main Menu

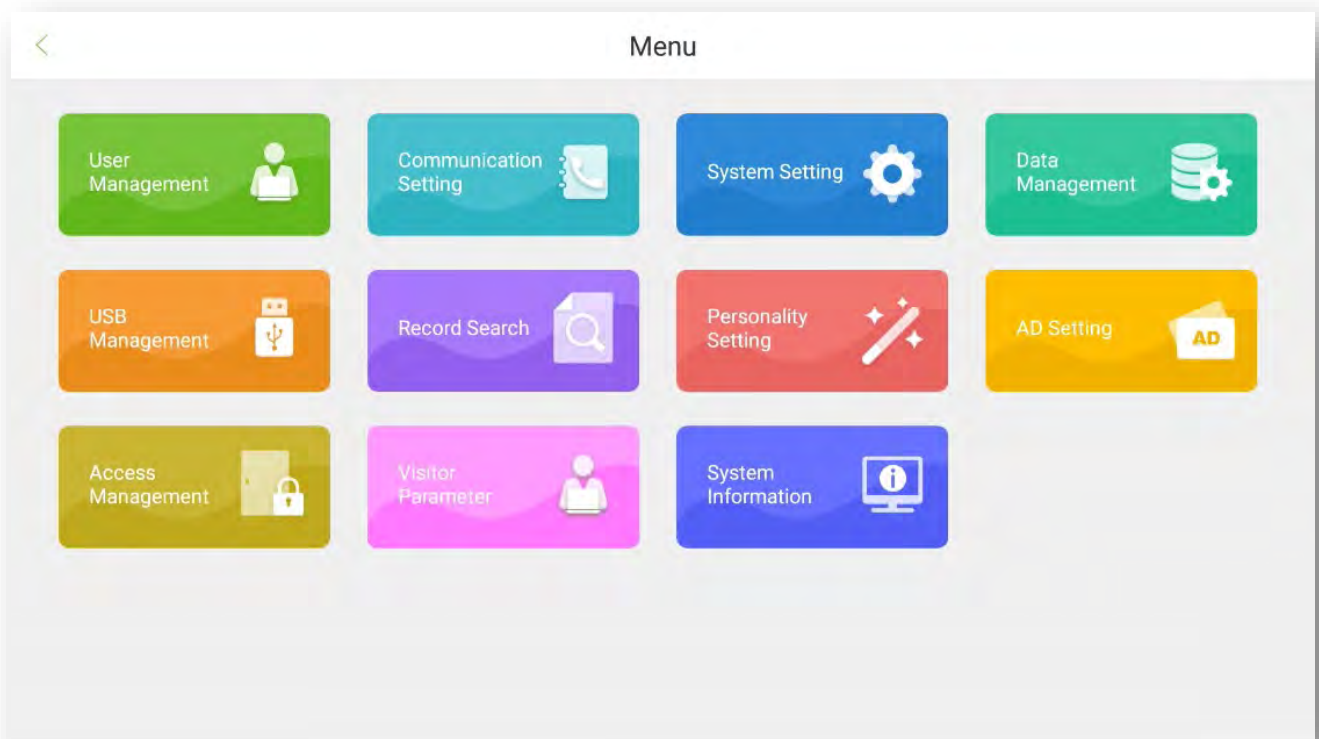

Menu	Function
User Management	Enables to view, add, edit, search and delete the basic employee information.
Communication Settings	Facilitates to set the communication parameters such as the Network, Wi-Fi, and PUSH.
System Settings	Allows configuration of system parameters including, Time & Date, Face parameters, and QR code address settings.
Data Management	Data management includes Data backup, Data restoration, and Clearing data.
U Disk Management	Uploads or downloads the data from a USB drive.
Record Search	Displays visitor records
Personality Settings	Sets display style for the device
AD Settings	Plays the Advertisement, sets the advertising frequency, etc.
Access Control Management	Sets the Access control parameters and Wiegand functions.
Visitor Parameter	Sets the Visitor parameters such as deletion of Visitor records, Detection management, etc.
System Information	Displays the device information like Data capacity, Firmware version, Android version, etc.

If the Super Administrator is not registered for the device, then click  to access the main menu. If the device has a Super Administrator, then his/her verification is required to access the main menu. For security purposes, it is advisable to register the Administrator while using the device for the first time.

3 Visitor Registration Process

3.1 Visitor Sign In

Click **SIGN IN** to start the visitor registration process.



3.1.1 Privacy Protection Policy

Before starting the registration process, the user may choose to skip the face registration process for privacy purposes. But by then, the user will not continue to use any facial recognition services, including Identity Match, Facial recognition check out, etc.

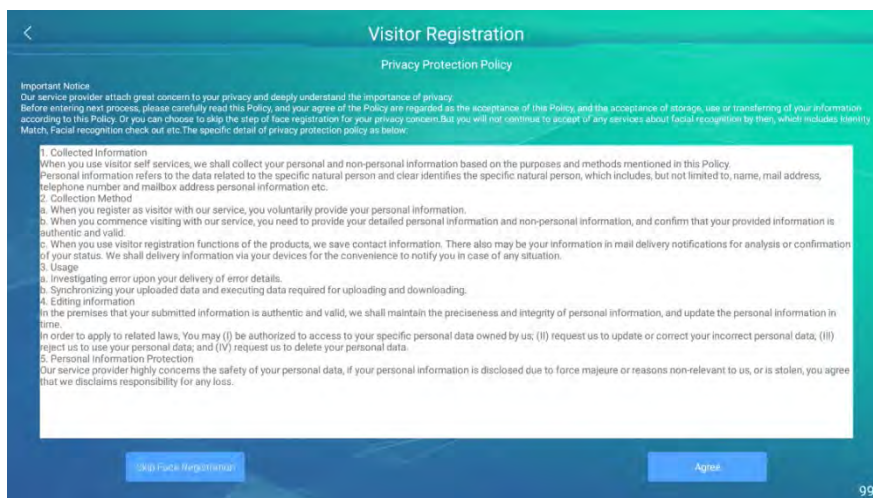

3.1.2 Face Registration

Visitors will register their faces and the recognized gender will be displayed. If the temperature screening function is turned on, the body temperature will be detected at the same time. After the registration process is successful, click **Next**. If the registration fails or you need to re-register, click the **Retry** button.

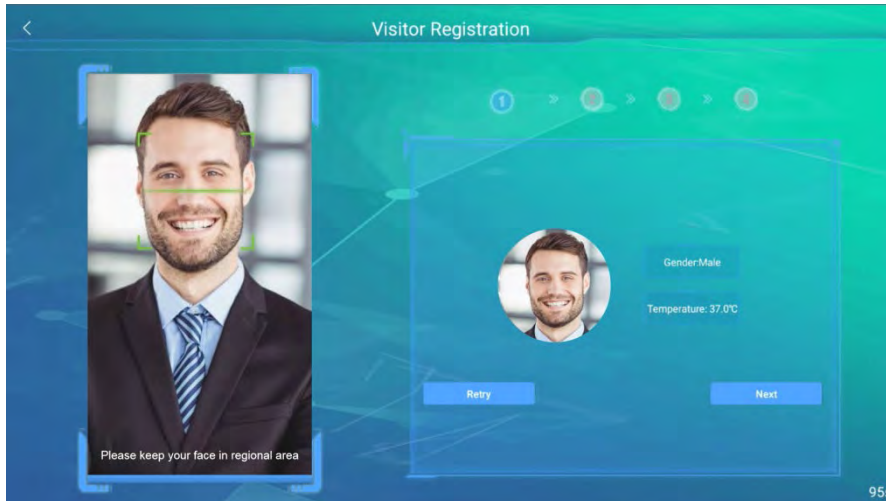

3.1.3 Declaration of Health Information

Visitors must complete the health information declaration. If the visitor has had a temperature test, the temperature value will be returned automatically. The next step can only be processed after the agreement is acknowledged. This function can be turned on or off in the Visitor Parameter.

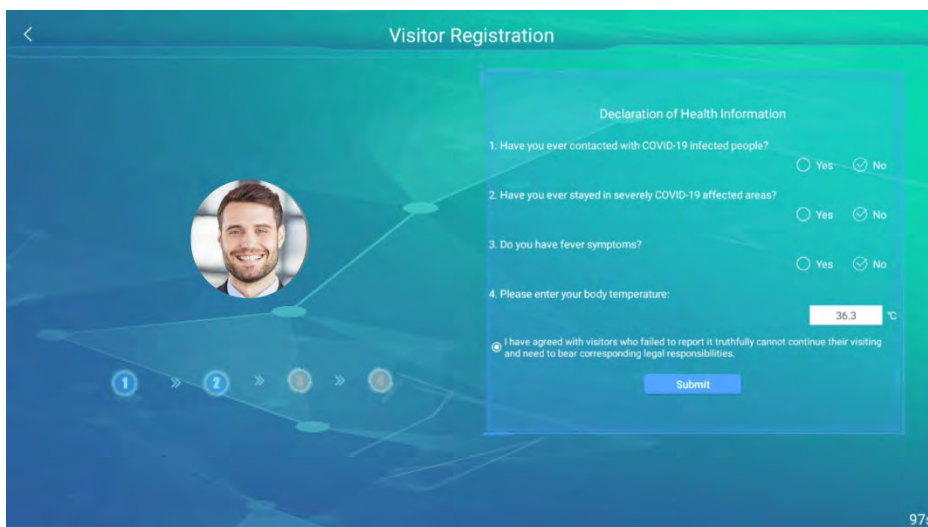

3.1.4 Visitor Information

The visitor must register the detailed information including First Name (required), Last Name, Phone Number (required), Company, Gender (required), Visit Purpose (required, issued by the software), Certificate Type (required), Certificate Number (required), Vehicle License Plate, E-mail address (required), and Carrying goods. Click **Next** to proceed further.



3.1.5 Host Information

The visitors may enter the First Name of the host to get the complete information automatically. Set the Visit Date, Start Time, and End Time (default is 23:59:59 of the day).

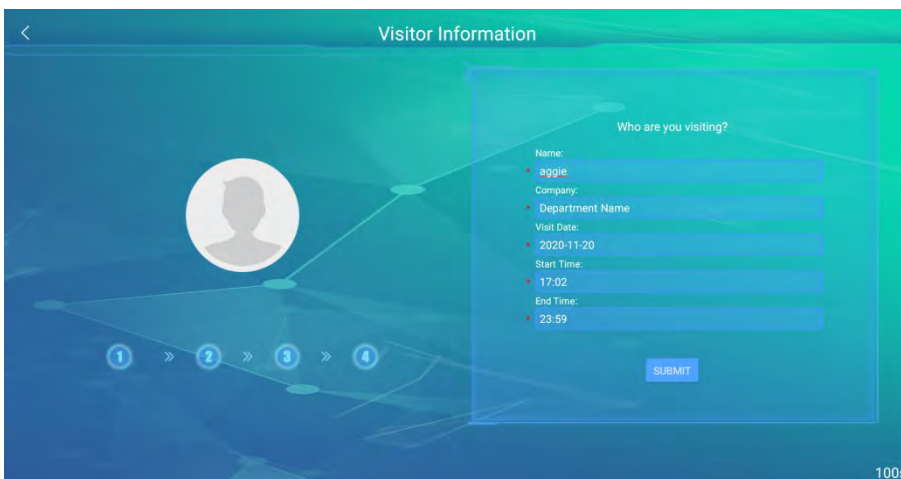

3.1.6 Volunteer Audit

The visitor should contact a volunteer to review the visitor registration information. Once the volunteer clicks **VOLUNTEER** and the verification is successful, click **NEXT**.

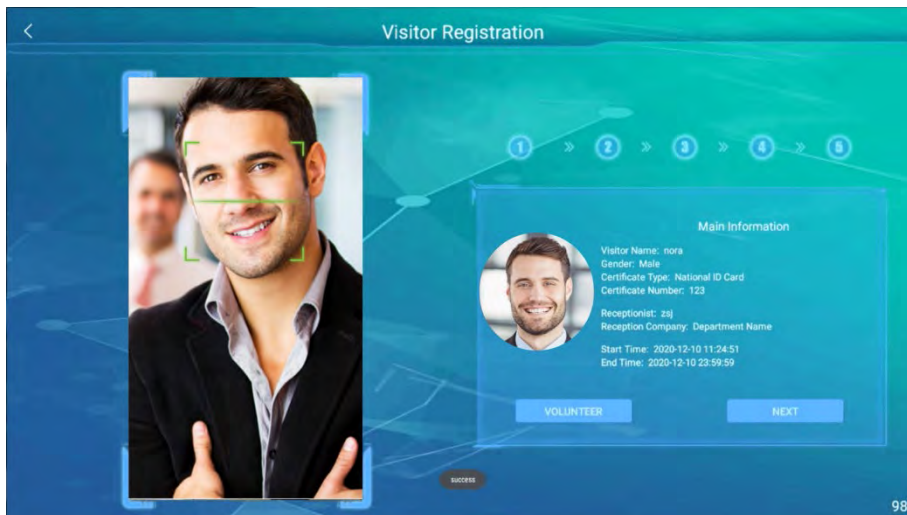

3.1.7 Complete Registration

After the Volunteer approves the registration, the visitor will enter the last interface. Click **Finish** to check the status of the review on the home screen. If no software review is required, the device will enter the **CHECK IN&OUT** interface directly for the visitor to check-in.

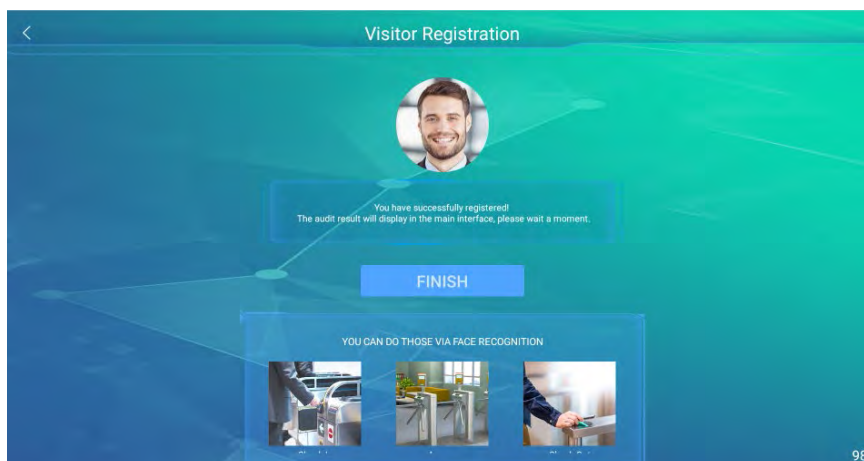

3.2 Visitor Query

The CHECK-IN & CHECK-OUT interface supports 3 methods for querying visitor records including face recognition, visitor QR Code, and Certificate number.

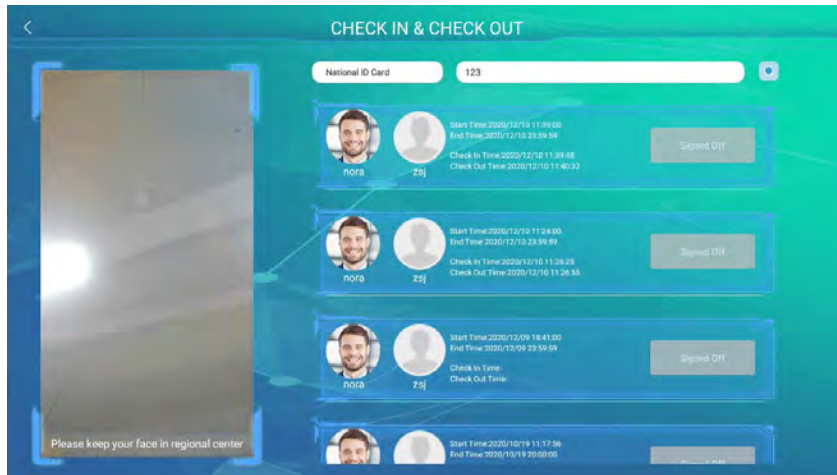

3.3 Visitor Check-In

Click **Check-In** on the CHECK-IN & CHECK-OUT interface after successfully registering the visitor information. If the device supports body temperature detection, it will detect the temperature. Only if the detected temperature is lesser than the threshold temperature check-in will be successful. Otherwise, the visitor cannot check-in, and an alarm will be triggered.

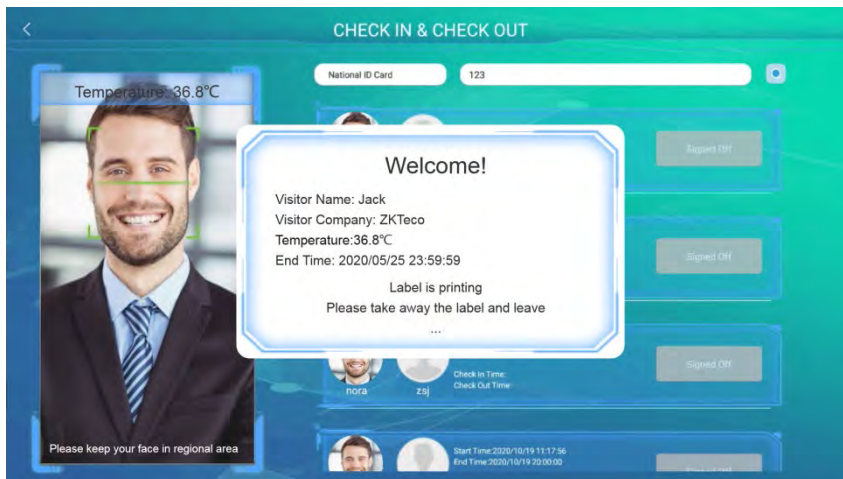

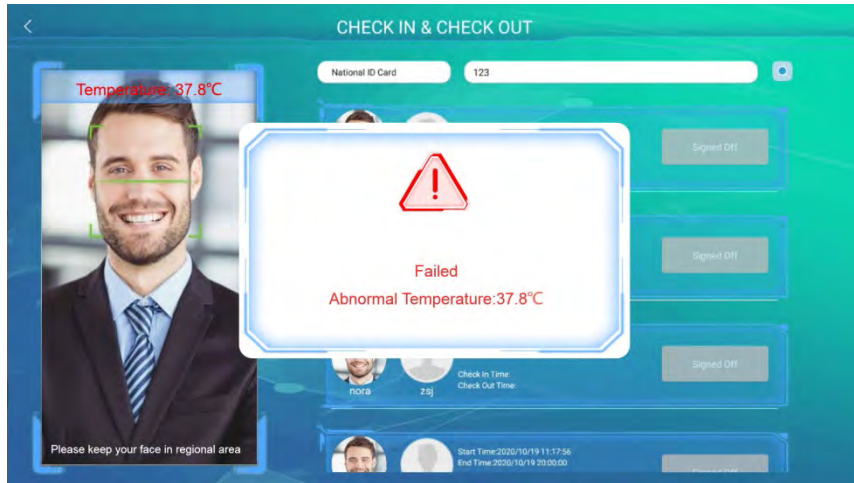

The visitor check-in will also fail when the printer runs out of paper while printing a visitor ticket.

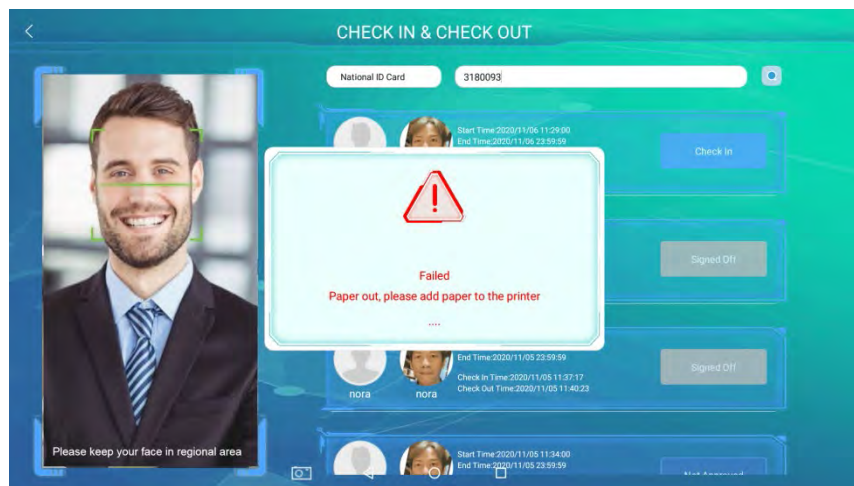

3.4 Visitor Check Out

Click **Check-Out** on the CHECK-IN &CHECK-OUT interface and the access privilege of the visitor will be deleted after check-out.

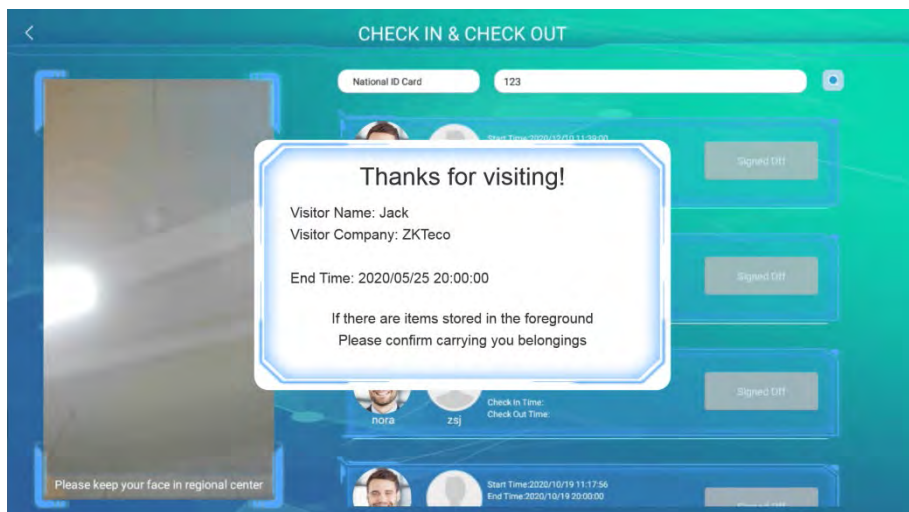

4 User Management

Open the main menu and select **User Management**. The user list displays the basic information of all the users, including their Names, User ID's, and images, as shown in the below image:

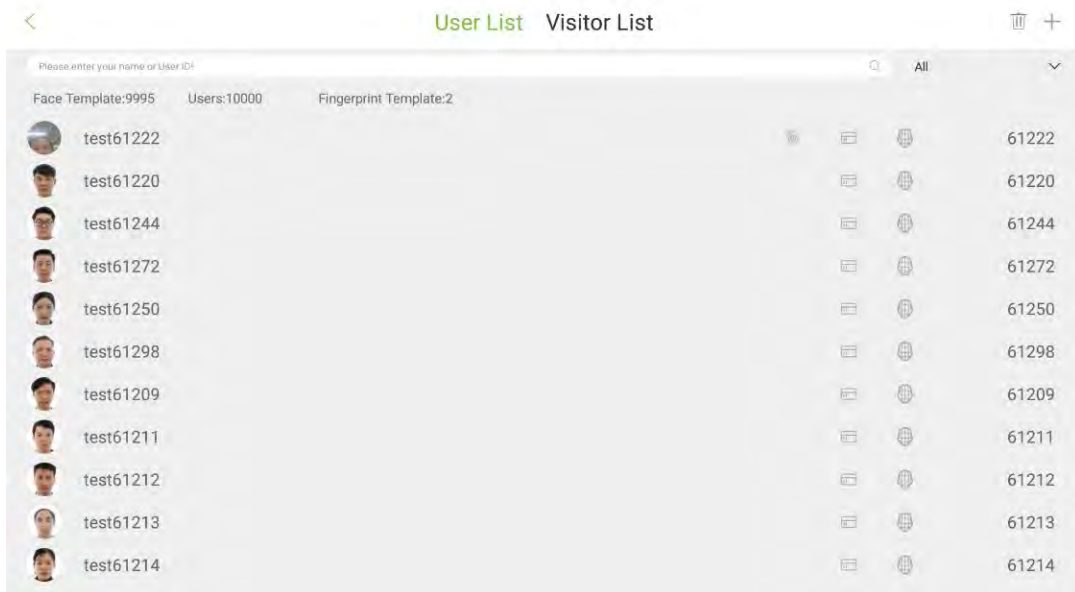

Click **Visitor List**. The visitor list displays the basic information of all the visitors, including their Names, User ID's, and images, as shown in the below image:

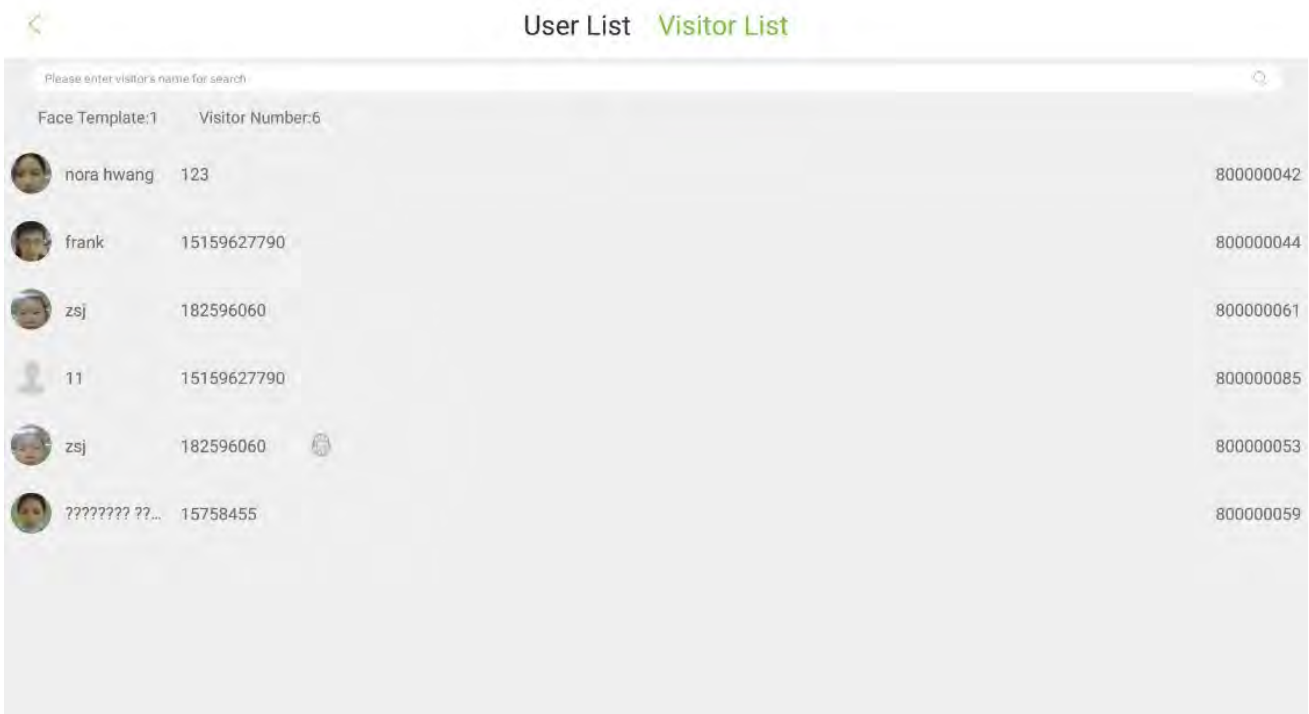

4.1 Add an Employee

Click < on the top left corner of the screen to return to the employee list screen. Click + on the top right corner to add a new user as shown in the below image:

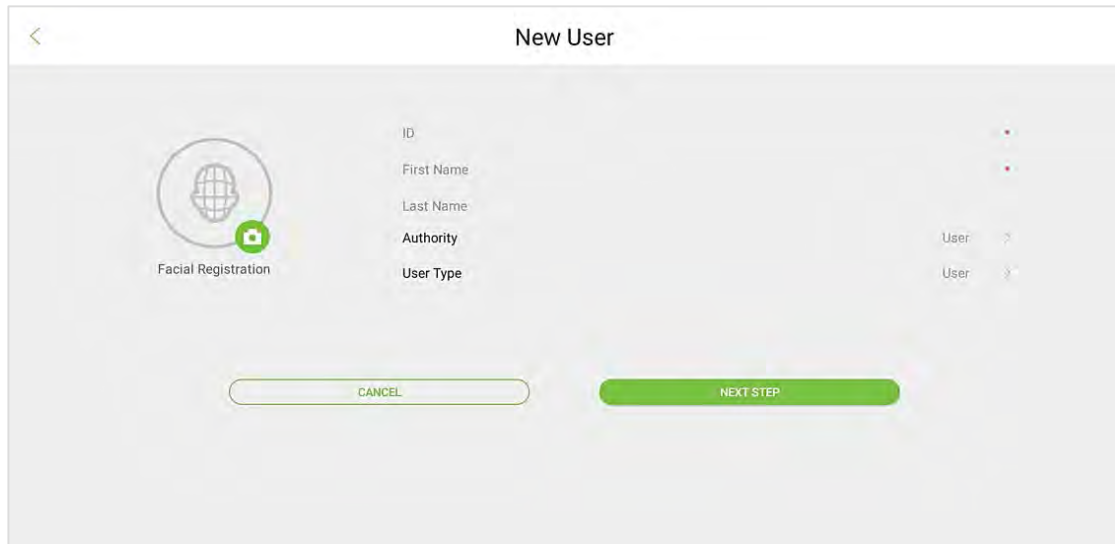

Description of the fields:

ID: Enter the Employee ID. It supports 1 to 9 digits by default. The message "Duplicated ID, please enter again." indicates that the ID number you have entered is already being used. Please enter a different ID.

Username: The username refers to the Employee's Name and the maximum length is 24 characters.

Authority: It includes the Normal User and an Administrator. After configuring an Administrator, administrator verification is required to access the main menu. An administrator can set up a password maximum of 6 digits.

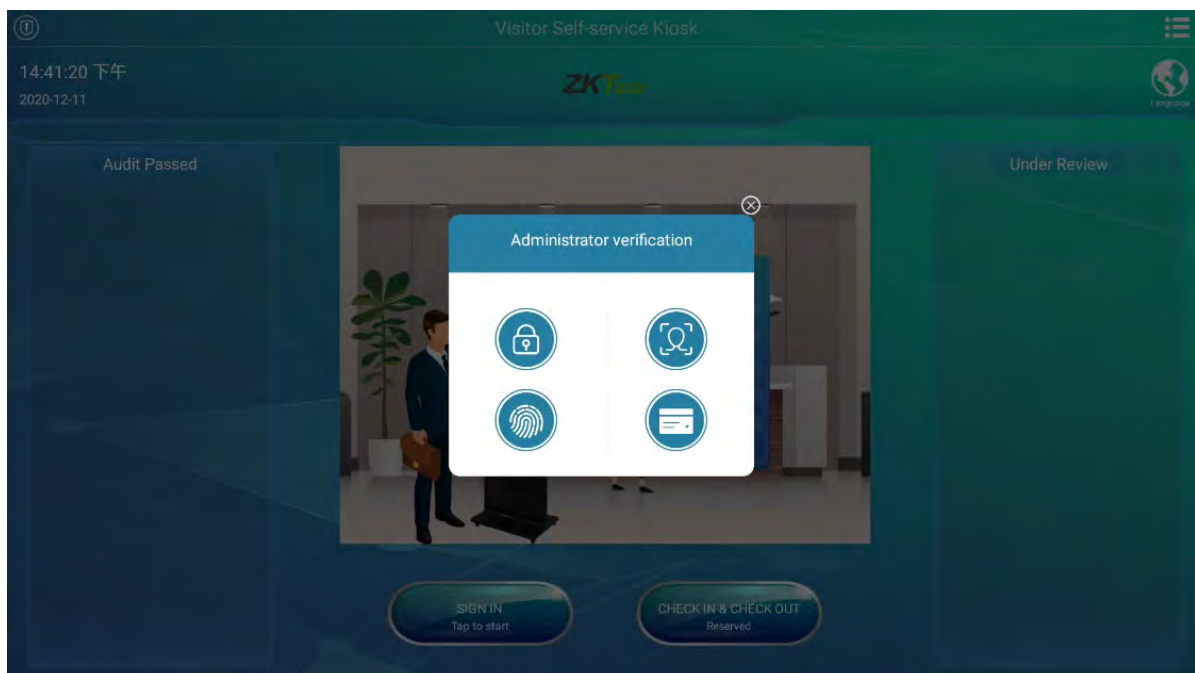

Identity Type: It includes Normal, VIP, and Blacklist. The normal identity type records the attendance of normal employees. The pop-up window varies for VIP and Normal Employees after verification. The user can customize these special settings in [Personality settings](#).

An employee cannot open the door by facial recognition if/she is blocklisted. The user can set the photo capture and alarm functions in [System settings](#).

Verification Method:

After entering the employee's basic information, tap **Next** to select the verification method.

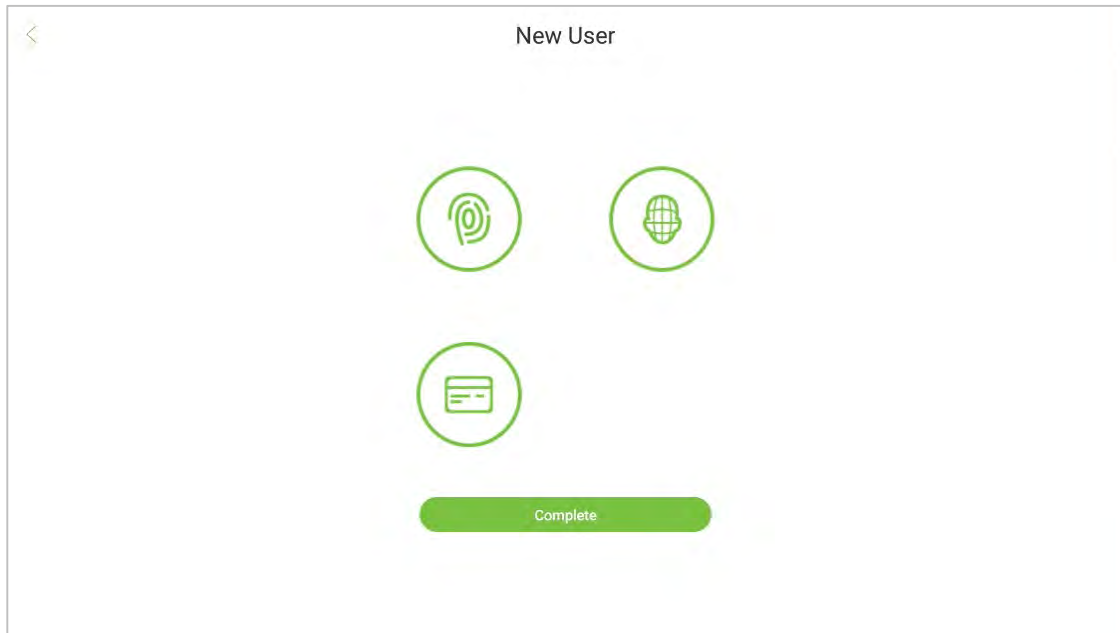

Face Registration:

Tap the  icon and then stand in the monitoring area. The registration is successful when the user's face is identified, and the photo will be saved.

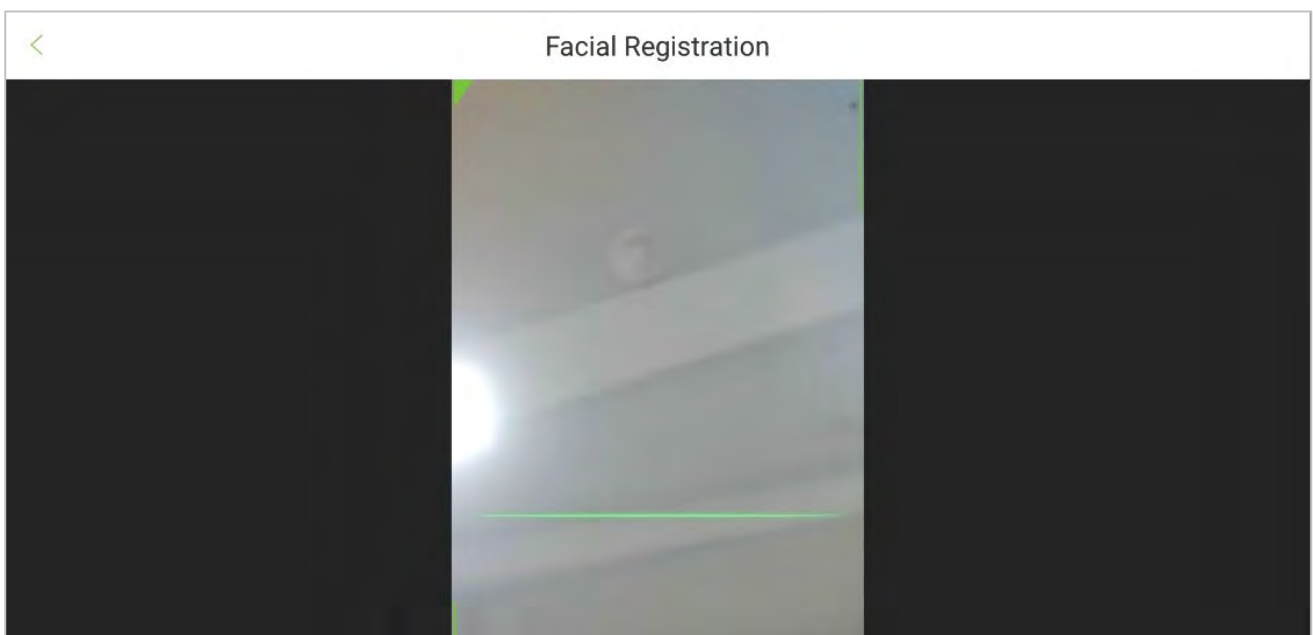

Fingerprint Registration:

Tap the  icon to open the fingerprint registration page. Press your finger to register the fingerprint.

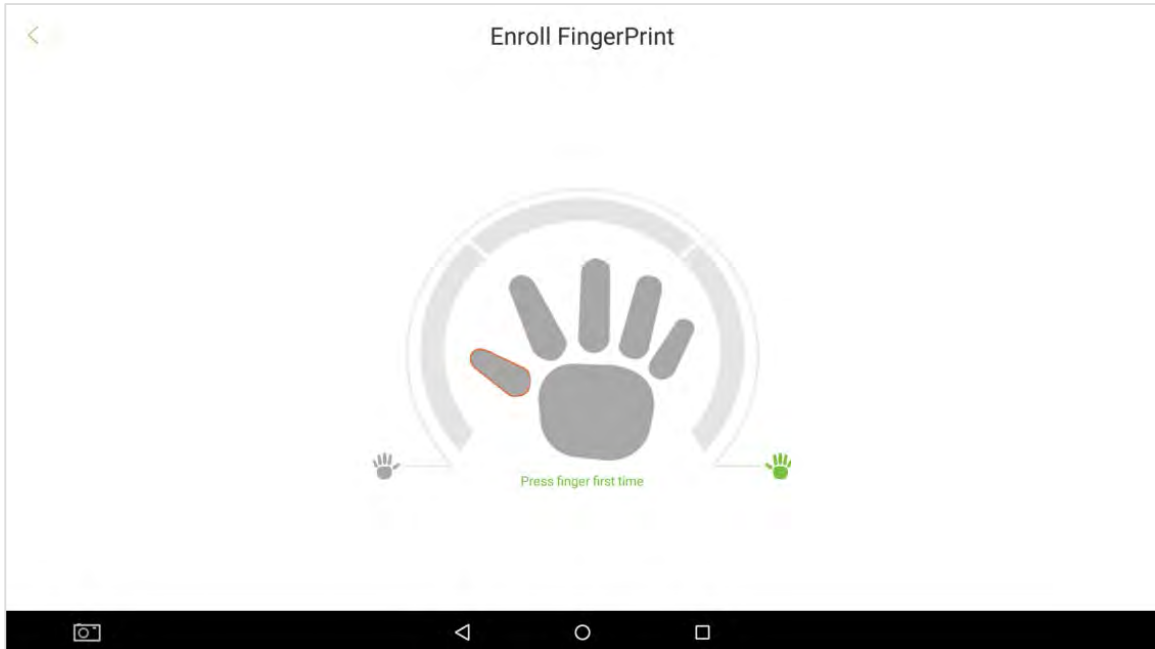

- Press your finger repeatedly until you see a green indicator that indicates a successful registration. If you press different fingers on the fingerprint scanner on successive verifications, the prompt "**Please use the same finger**" appears on the screen.
- Once the fingerprint has been registered successfully, a dialog box appears as "Continue to enroll the next fingerprint?". Tap **Yes** to register the next fingerprint, or **No** to return to the fingerprint registration page.

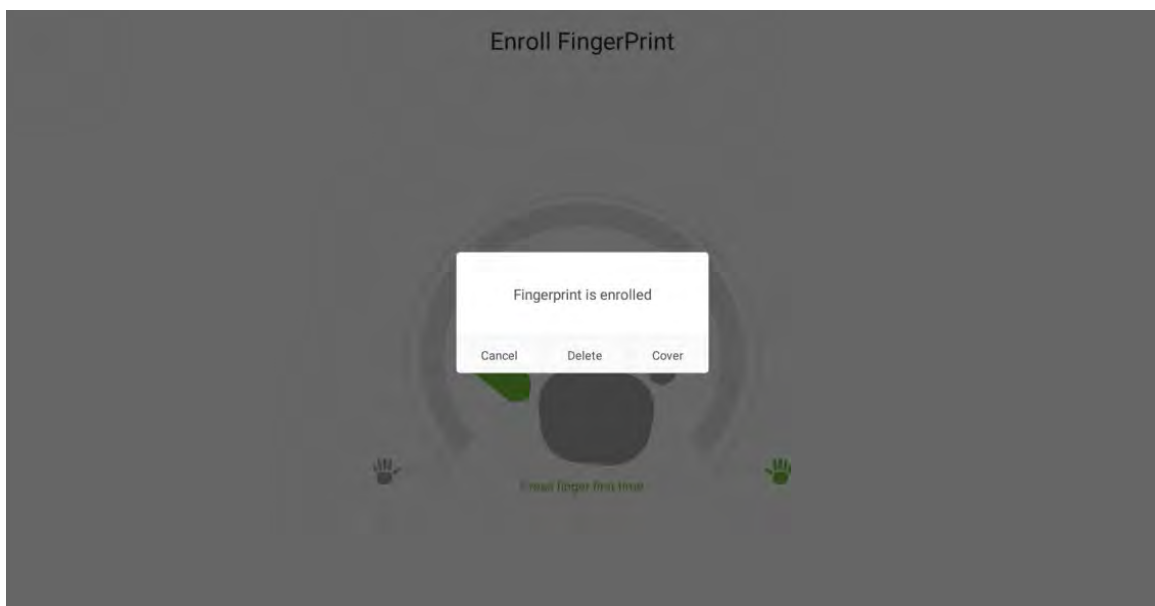

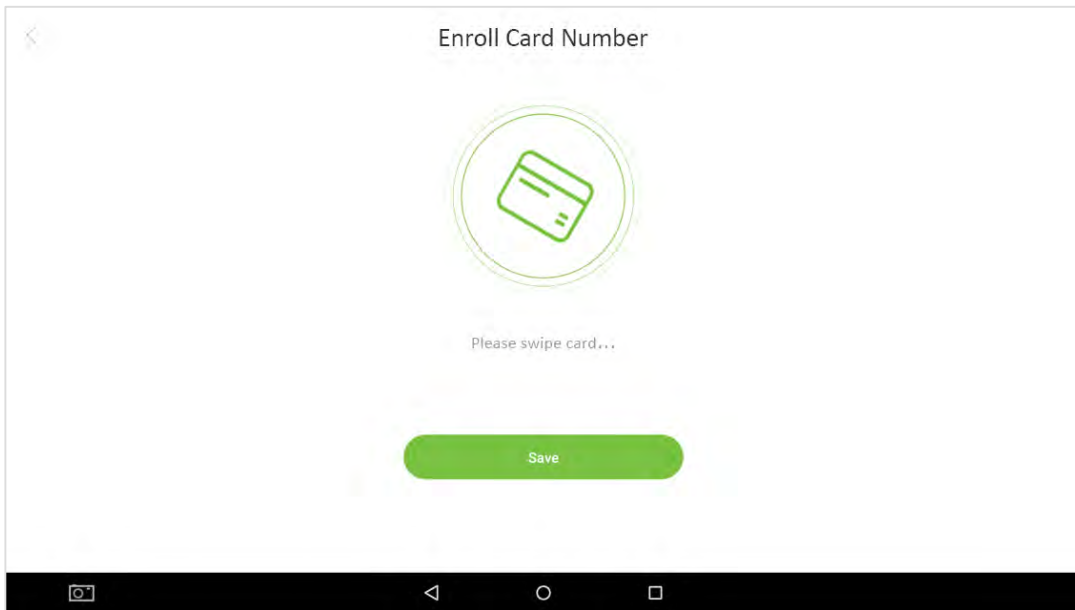

Card Registration:

Tap the  icon to open the card registration page. Place your card close to the card swiping area.



4.2 Delete an Employee

- Tap the  icon on the top right corner to initiate the deletion process.
- Select the employee to be deleted and tap the  icon.

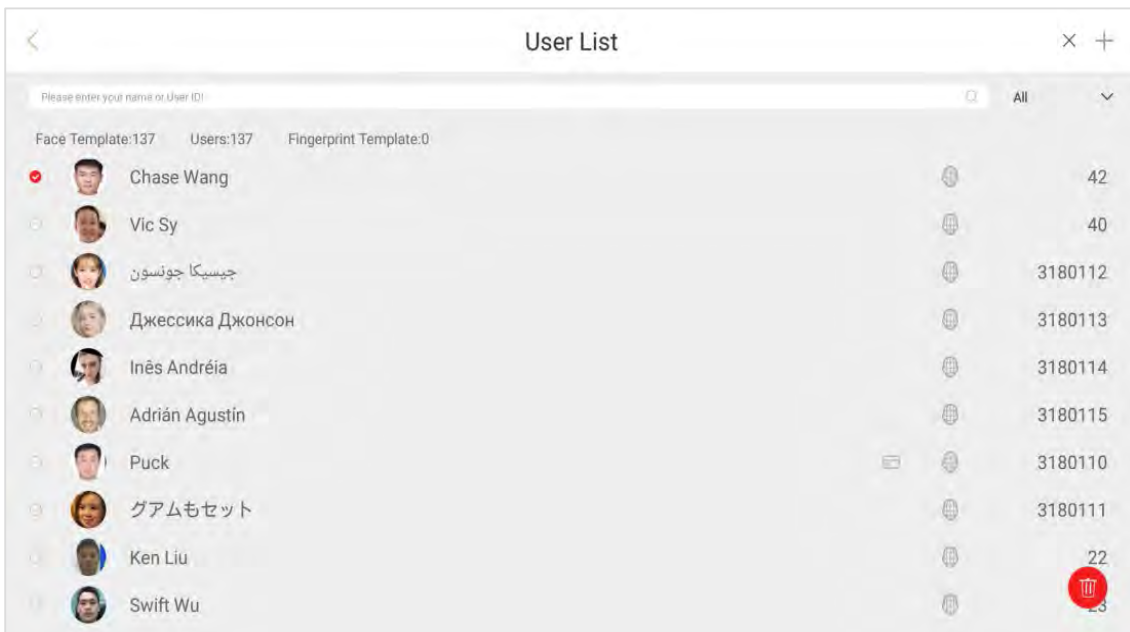

5 Communication Settings

To enable the communication between the device and the PC over a network, it is necessary to set the communication parameters on the device.

5.1 Wi-Fi Settings

Open **Communication Settings** → **Wi-Fi** to set the Wi-Fi parameters.

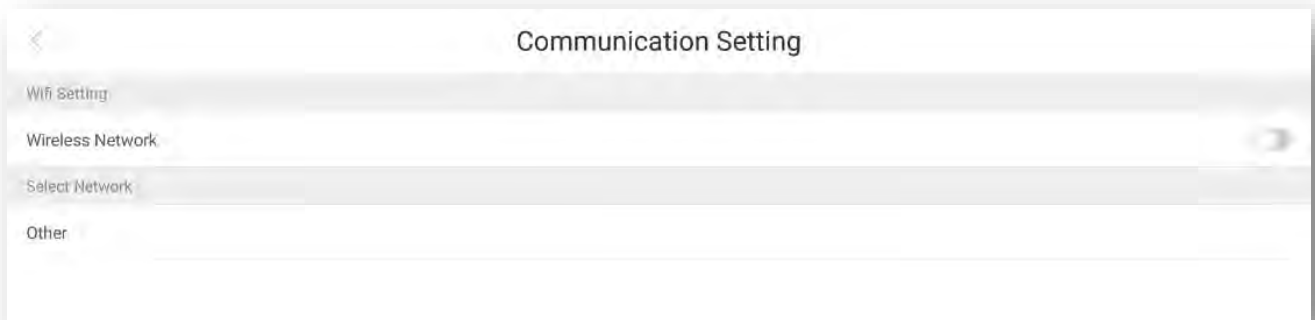

5.2 Ethernet Settings

Open **Communication Settings** → **Ethernet** to set the LAN parameters.

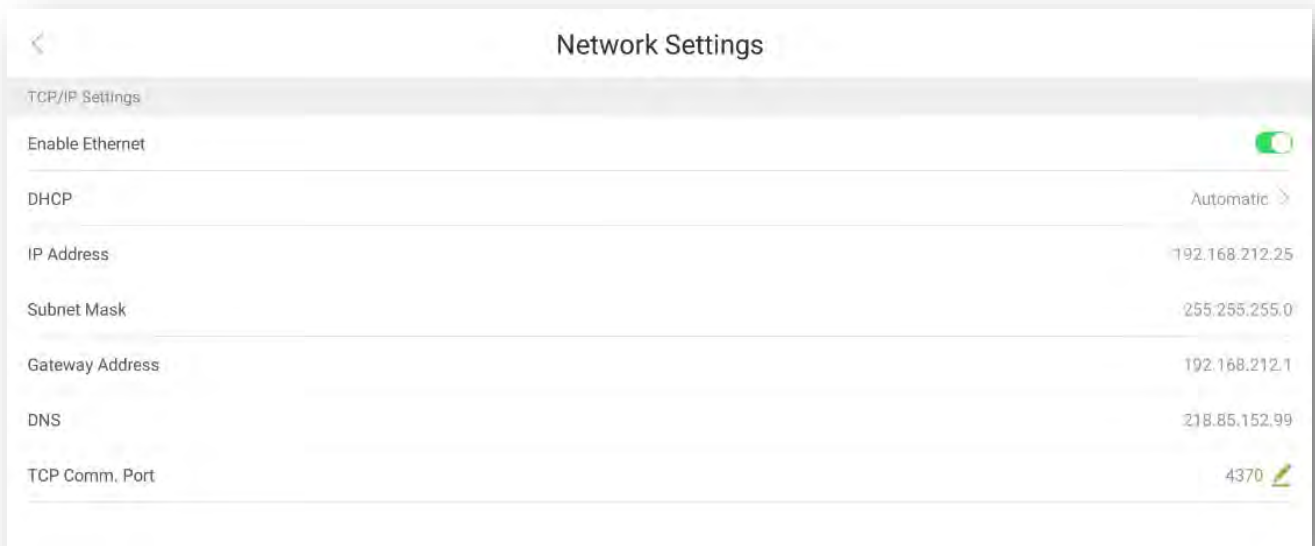

Field	Description
Ethernet	Enable/Disable the Ethernet connection.
IP Address	The default IP Address is 192.168.1.201.
Subnet Mask	The default Subnet Mask is 255.255.255.0.
Gateway	The default Gateway Address is 0.0.0.0.
DNS	The default DNS Address is 0.0.0.0.
DHCP	Assigns dynamic IP Addresses to the network clients over a Server.
IP Mode	Displays the mode of IP Address. It can be static or dynamic.

5.3 Server Settings

Open **Communication Settings** → **Software Server Settings** to set the parameters for connecting the PUSH Server.

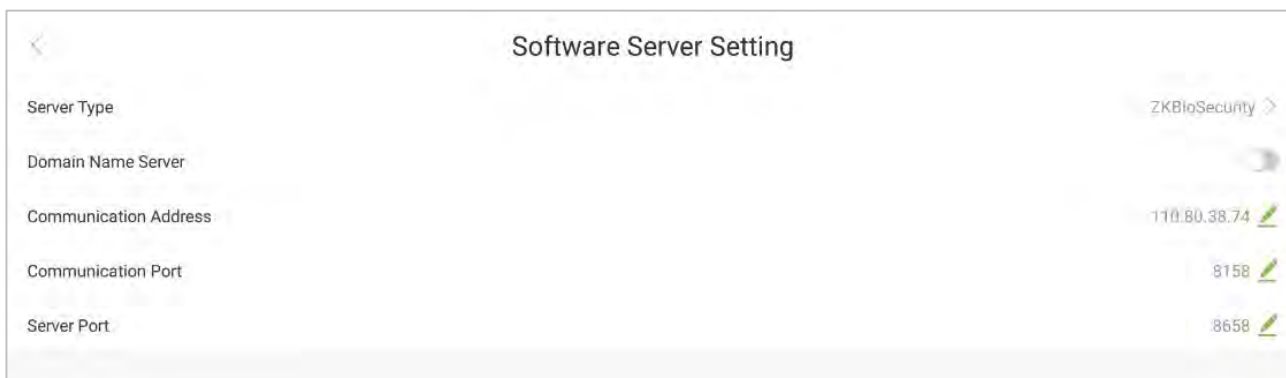

Field	Description
Server type	Select the software you want to connect: E.g.: BioTime, ZKBioSecurity.
Domain Name Server	Enable the Domain Name Server.
Communication Address	Set the IP Address of the software.
Communication Port	Set the Communication Port of the software.
Server Port	Set the Server Port of the software.

6 Visitor Parameter

The Visitor Parameter is used to define the aspects related to their visit.

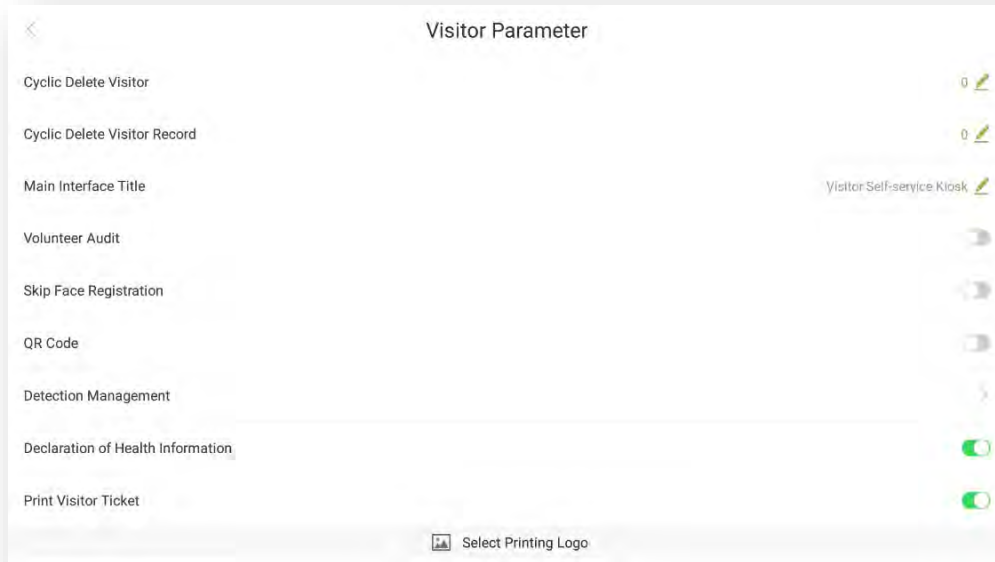

Field	Function
Cyclic Delete Visitor	Here, the user can set to delete the visitor details in the system when the memory is full. The default value is 0 which means the details must not be deleted. The range is 0 to 1000.
Cyclic Delete Visitor Record	When the visitor record memory is full, the user can set it to delete the oldest records. The default value is 0 which means the records must not be deleted. The range is 0 to 10000.
Main Interface Title	The main screen title can be customized as per the requirements. The maximum length is 24 characters.
Volunteer Audit	If this function is enabled, a volunteer review is necessary to register a visitor.
Skip Face Registration	The visitor registration process will not have a face registration step and no privacy agreement will be shown if this feature is enabled.
QR Code	If this feature is enabled, the main interface will display a QR code.
Detection Management	Set the appropriate parameters of the temperature screening module to enable or disable the temperature screening feature.
Declaration of Health Information	If this function is enabled, the visitor registration process will have the visitor health information declaration step.
Print Visitor Ticket	If this function is enabled, the device will print the visitor ticket after check-in.

Select Logo

The device supports the display of a custom logo image on the main interface title. It will be printed on the visitor ticket too.
(Upload logo in the U disk management)

6.1 Detection Management

Open **Visitor Parameter** → **Detection Management**.

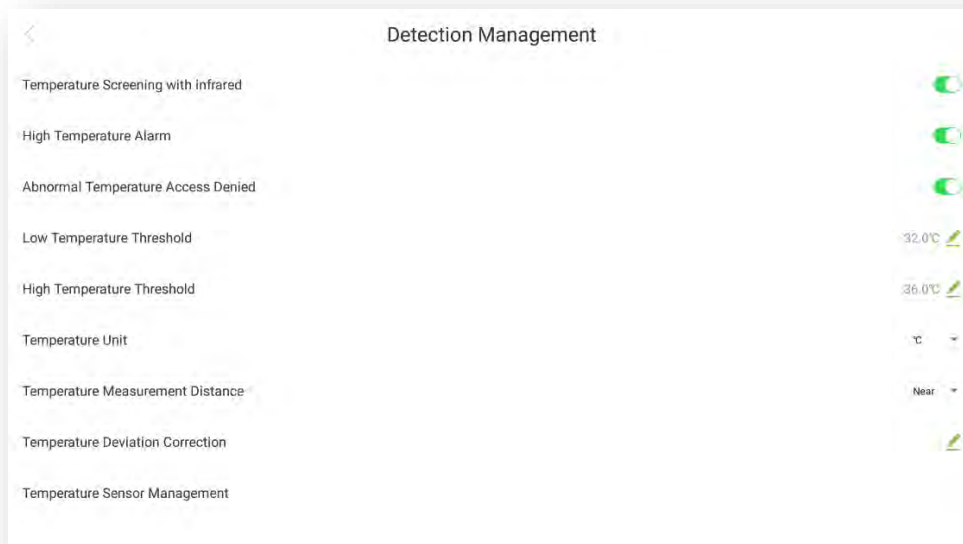

Description of fields:

Temperature Screening with Infrared: When the feature is enabled, the device will screen the body temperature of visitors while registering the face.

Low-Temperature Alarm Threshold: If the temperature detected is lower than the set value, the data will be considered invalid and will not be included in the final temperature value.

High-Temperature Alarm Threshold: When the temperature detected is higher than the set value, the device will trigger an alarm when the visitor checks-in, and the temperature result will be displayed in red.

Abnormal Temperature Access Denied: When the temperature detected is higher than the threshold value, the device will deny visitor check-in.

Temperature Deviation Correction: Set the compensation value of the temperature detection data. The deviation value can be positive or negative.

Temperature Unit: Set the temperature unit as Celsius or Fahrenheit.

Temperature Measurement Distance: Set the temperature measurement distance as Close / Near / Far.

Temperature Sensor Management: Displays the MCU version of the temperature detection module.

7 System Settings

System Settings facilitate setting the system parameters based on your requirements.

7.1 Time and Date

Open **System Setting** → **[Date & time]**.

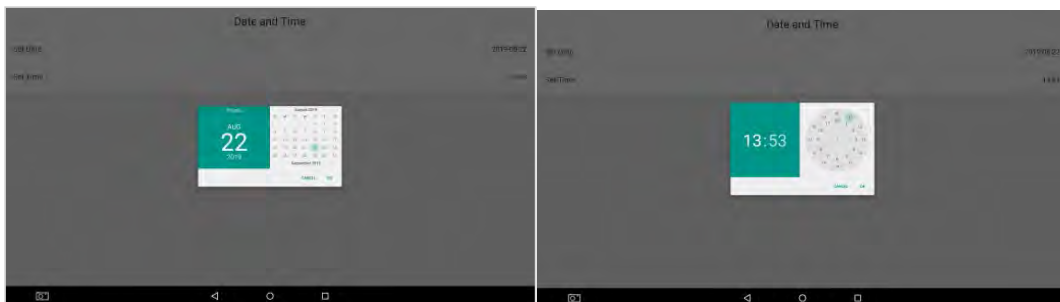

- Set the Date, Month, and Year on the calendar and tap **OK**.
- Move the Hour and Minute hands to set the time and tap **OK**.

7.2 Menu Timeout

Open **System Setting** → **Menu Timeout**.

When the Administrator logs into the device and no operation is performed within the menu timeout period, the device will automatically switch back to the home screen.

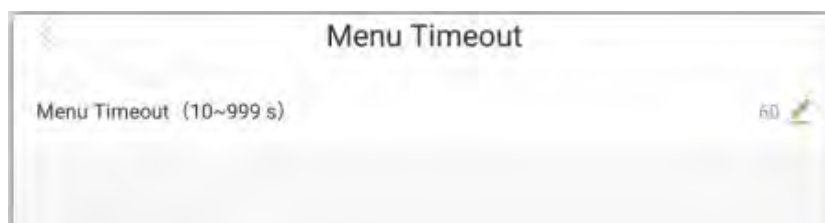

7.3 QR Code Settings

Open **System Setting** → **QR Code Setting**.

The users can set the URL address in two ways:

Synchronize from Cloud Server

When you choose to synchronize from the Cloud Server, the QR code address will be retrieved from the background Server. After setting the Server, use your phone to scan the QR code on the home screen. The visitor registration screen will be displayed on the phone. The QR code displayed on the device will automatically obtain the device's serial number information.

Custom Address

While choosing the Custom Address mode, the user can enter a valid URL address as the QR code address. E.g.: <http://www.zkteco.com/en>.

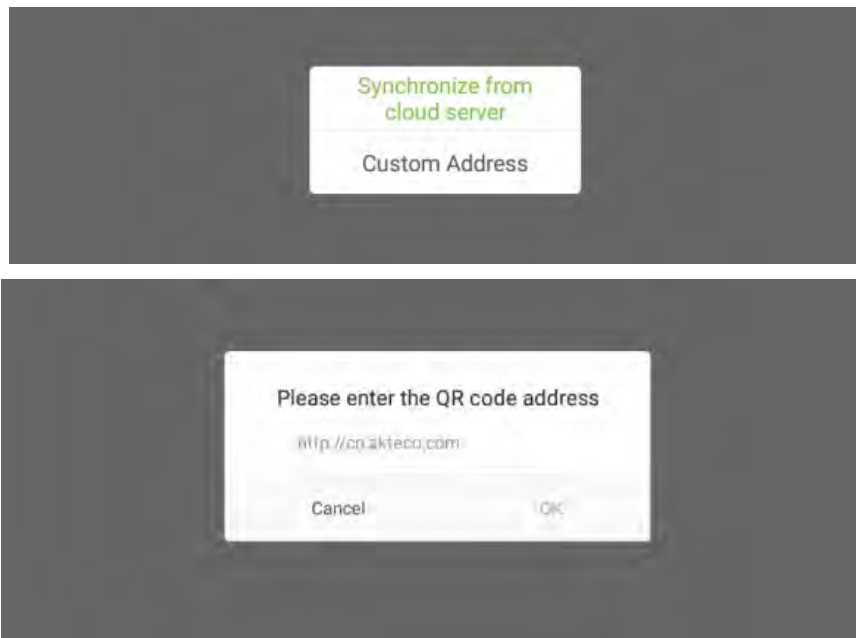

8 Data Management

Tap **Data Management** on the main menu to perform data management operations such as Deletion, Restoration, and Data backup.

8.1 Clear Data

Open **Data Management** → **Clear Data** to delete the data.

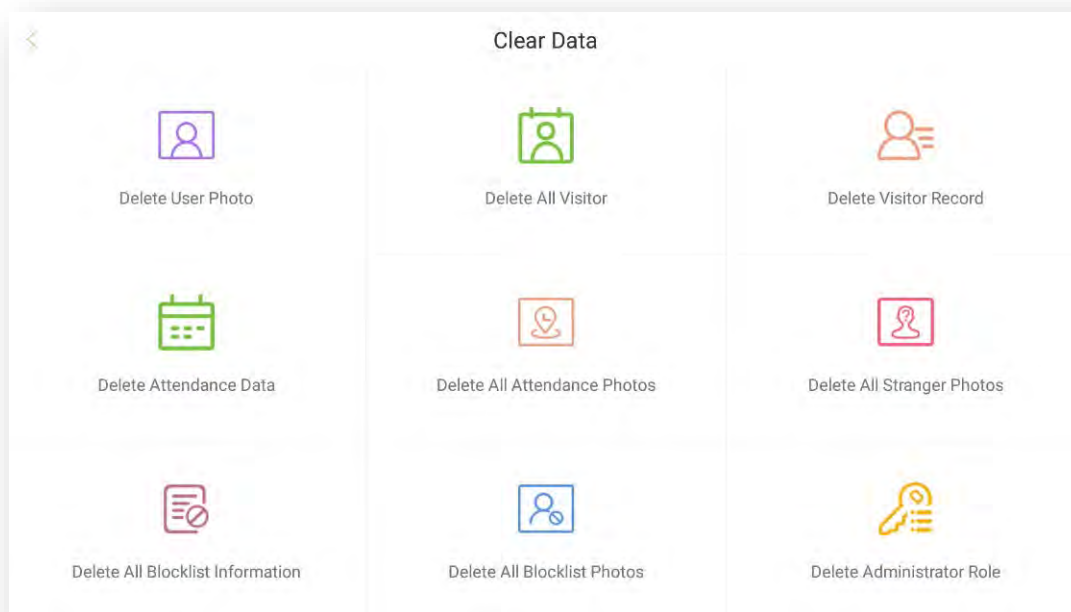

Description of fields:

Delete Attendance Data: Deletes all the attendance records in the device, or data in a specific time period.

Delete User Photo: Deletes all the user photos from the device.

Delete All Visitor: Deletes all the visitor details from the device.

Delete Visitor Record: Deletes all the visitor records from the device.

Delete Advertisement Information: Deletes all or some specific advertisement pictures from the device.

Delete all Attendance Photos: Deletes all the attendance photos from the device.

Delete all Blocklist information: Deletes all the blocklisted records from the device.

Delete all blocklist photos: Deletes all the blocklisted photos from the device.

Delete all stranger photos: Deletes all the stranger's photos from the device.

Delete Administrator role: Deletes the authority of a specific administrator from the device.

Delete Logo: Deletes the selected logo pictures from the device.

Delete Wallpaper Photos: Deletes the selected wallpaper pictures from the device.

Delete all data: Deletes all the data from the device.

8.2 Backup Data

Open **Data Management** → **Backup & Restore** → **Data Backup**.

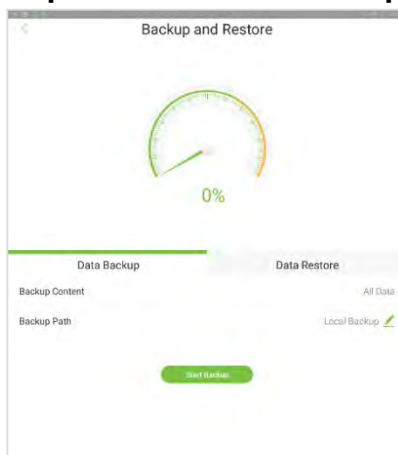

Menu	Function
Backup content	Backs-up all the data by default.
Backup path	Set the backup path as Local backup/U-disk backup . Local backup: Backs-up the data to the specific path of the device by default. U-disk backup: Backs-up the data to the USB disk inserted into the device.

After setting the details, tap **Start backup** to back up the content to the specific path of the device or the U-disk.

8.3 Restore Data

Open **Data Management** → **Backup & Restore** → **Data Restore**.

Menu	Function
Restore content	Restores all the data by default, and data cannot be retrieved.
Restore path	Set the path as Local backup/U-disk backup . Local backup: Backs-up the data to the specific path of the device by default. U-disk backup: Backs-up the data to the USB disk inserted into the device.

After setting the details, tap **Start restore** to restore the data in the device or U-disk.

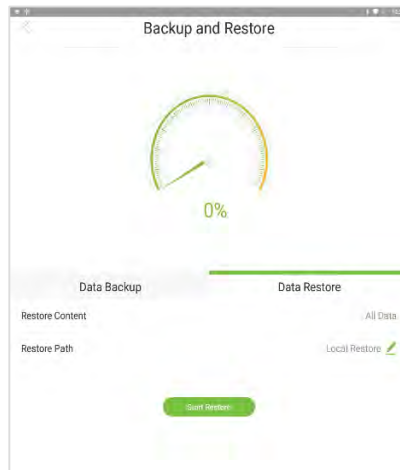



9 USB Management

Tap **USB Management** on the main menu. Insert a USB drive into the USB port of the device before uploading/downloading the data.

9.1 Uploading Data from the USB drive

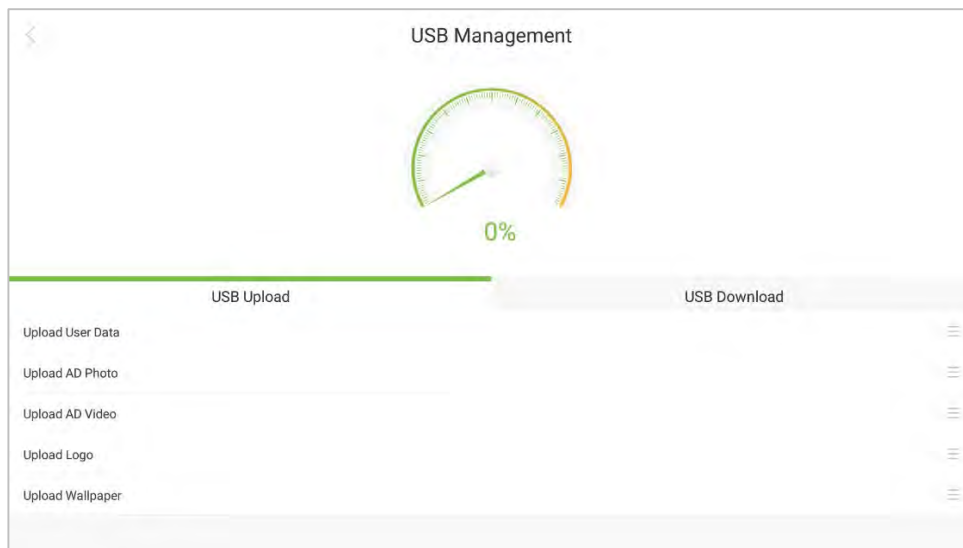
Select **U-disk Management** → **USB upload**. The interface to upload the data from the USB drive will be displayed as shown below:



Menu	Function
Upload User data	Uploads the user information from the USB drive to the device.
Upload AD Photo	Create a folder in the root directory of the USB drive named "ad". Then, create a new folder named "picture" inside the folder "ad" to save the pictures for advertisements. The supported picture formats are JPG, BMP, GIF, and PNG.
Upload AD Video	Create a folder named "video" inside the folder "ad" to save the video advertisements. The supported file formats are AVI, 3GP, WMV, FLV, MP4, MKV.
Upload Logo	Create a folder named "logo" to save the logos to be printed. The supported file formats are JPG, BMP, and PNG. The recommended file type is BMP with 1-bit depth.
Upload Wallpaper	Create a folder named "wallpaper" to save the photos. The supported file formats are JPG, BMP, and PNG. The recommended wallpaper size is 1920*1080.
 You can only select advertising pictures or advertising videos at a time.	

10 Record Search

Tap **Record Search** on the main menu to search the required records in the Facekiosk device.

10.1 Visitor Record

Select **Record Search** → **Visitor record** to view all the visitor records in the device. Tap  to filter the records accordingly as shown below:

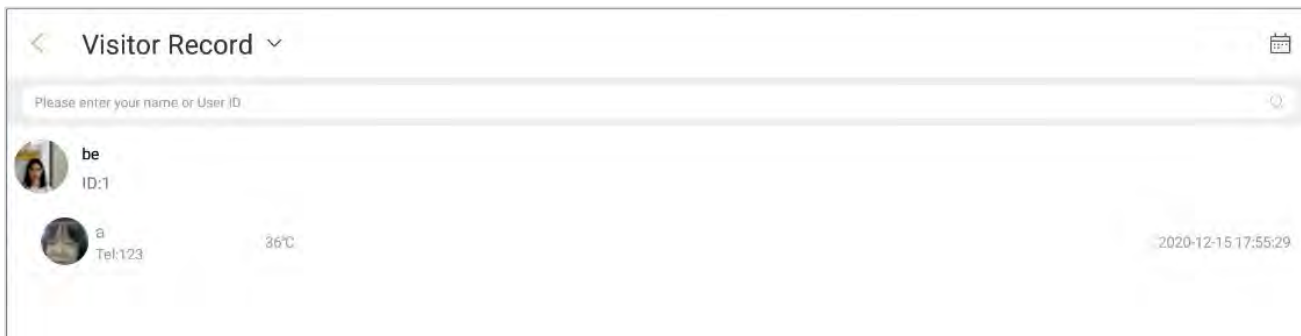

 The sub-list is the visitor information, and the parent-list is the host information.

11 Advertisement Settings

Open **AD Setting** → **Turn on AD Player** to turn on the Ad player. When it is switched on, you can set the switching time of the advertisement photo/video if the face is not detected. The features of Ad settings are given below:

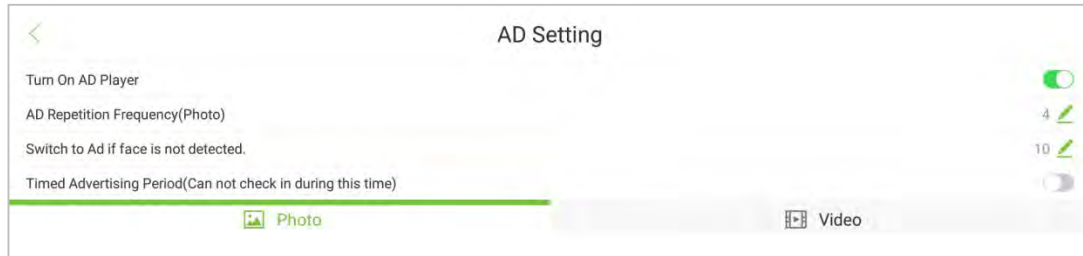

Description of fields:

Ad Reception Frequency: Set the repetition frequency of the Advertisements.

Switch to Ad if face is not detected: Set the time duration after which the advertisement picture/video will be displayed if the face is not detected.

Advertisement Playing Time: Set the time period for the advertisement. If the advertising time span overlaps with the meeting's check-in/check-out time range or check-in/check-out time of individuals, when someone's face is identified in the monitoring area, the system switches to the face check-in interface and then switches back to the advertising interface when there is no check-in.

12 System Information

The **System Information** menu allows you to view the device storage and version information.

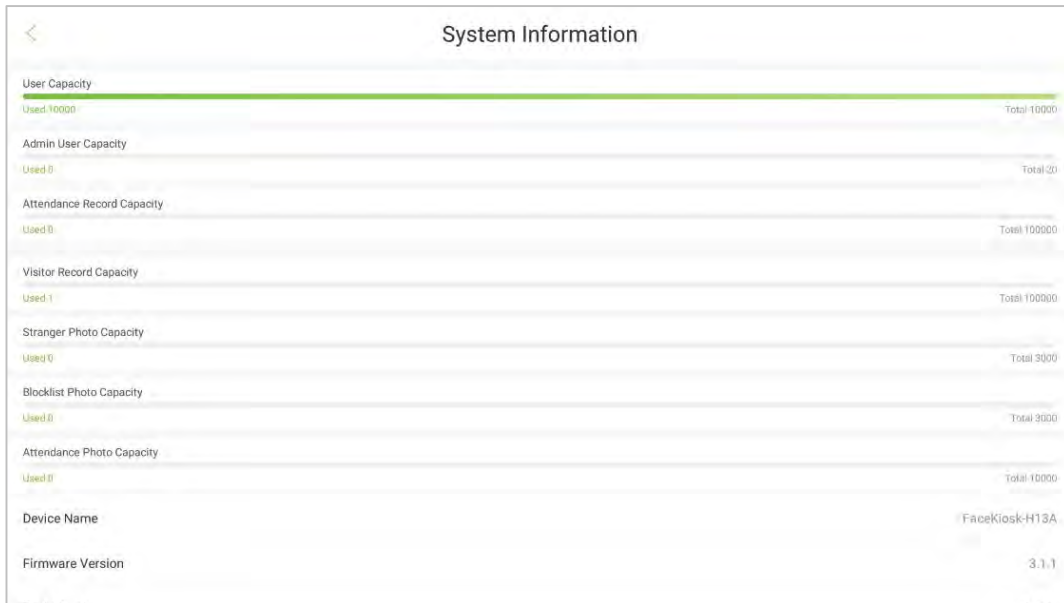

Usage: The storage information includes User capacity, Admin capacity, Visitor Record capacity, Attendance Record capacity, Stranger Photo capacity, Blocklisted Photo capacity, and Attendance Photo capacity.

The device information includes Device Name, Firmware version, Push version, Face Algorithm version, Fingerprint Algorithm version, Serial Number, MCU version, Platform version of the device.

Check for Update: The device supports online updates for the firmware. Click here to check if there is a new firmware version for updating. The device is required to be in the WAN environment for the update.

13 ZKBiosecurity Connection

The device is designed to connect with the FaceKiosk module of the **ZKBioSecurity Software**.

13.1 Adding a Device

Perform the following steps to add the device to ZKBioSecurity software.

1. Open the ZKBioSecurity software then select FaceKiosk → **Device** → **Search Device** → **Add**.

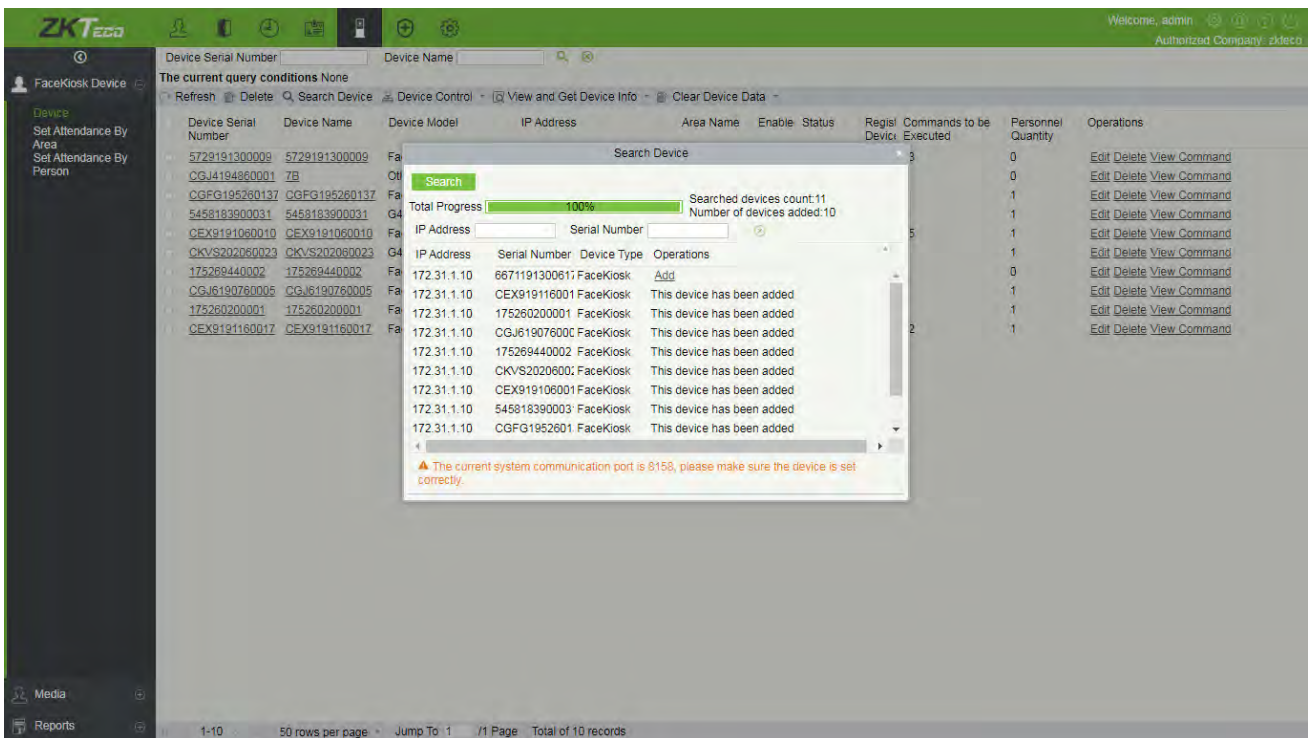

13.2 Visitor Management

13.2.1 Set the FaceKiosk as an Entry Point

In the Visitor module, select the FaceKiosk device that has been added in the FaceKiosk module as an entry place.

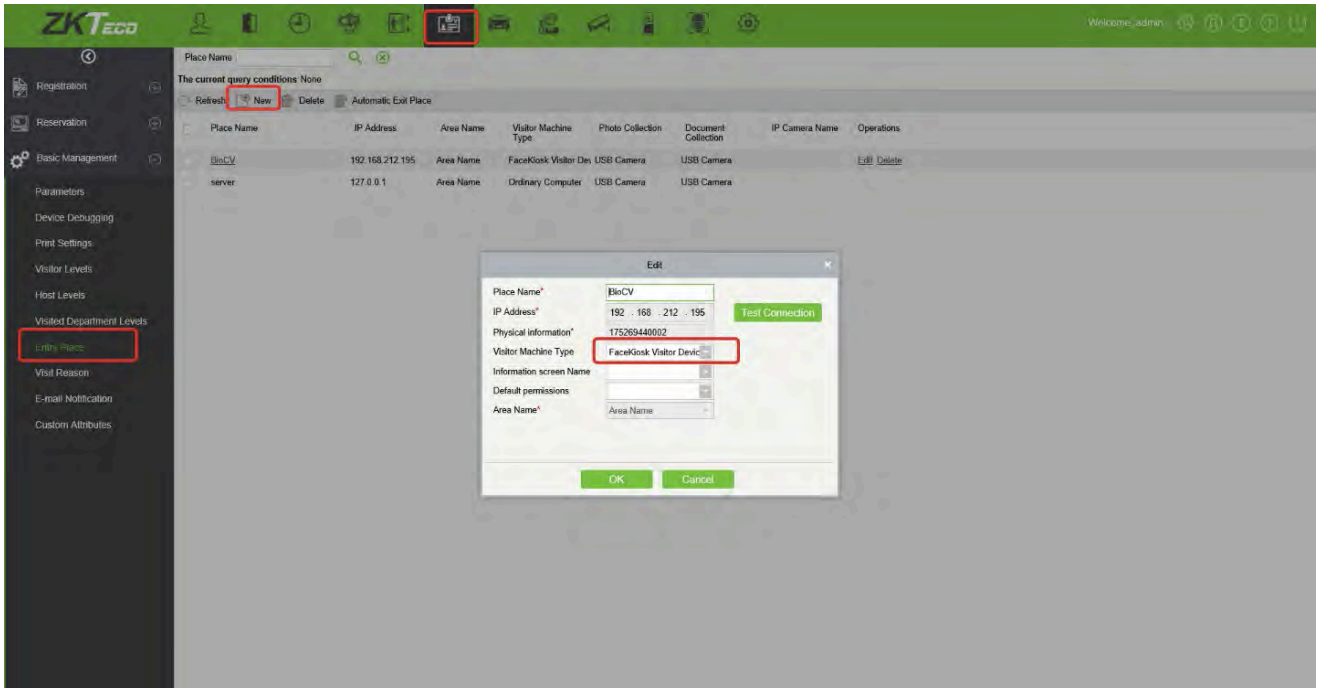

13.2.2 Host Settings

Add the person in the Personnel module, and then select the person who needs to be set as the host in the [Visitor Module] → [Host Level].

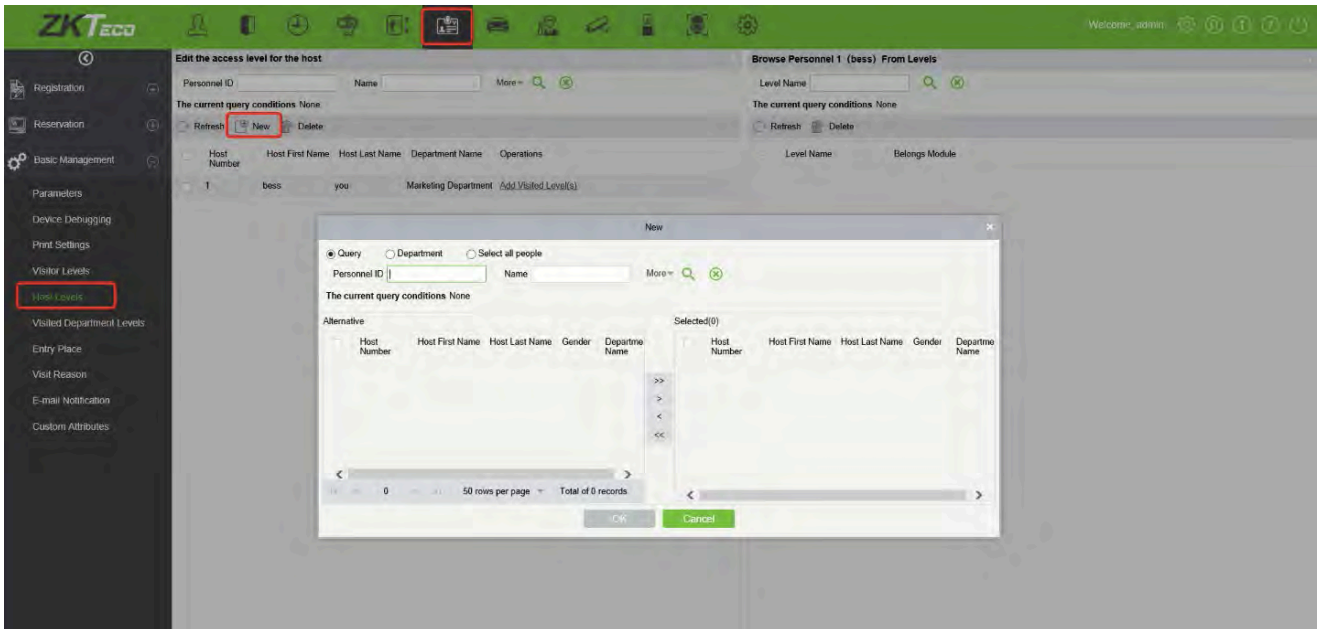

13.2.3 Visit Reason Settings

Add the purpose of visit in **[Visitor Module]→[Visit Reason]**. It will synchronize to the device automatically.

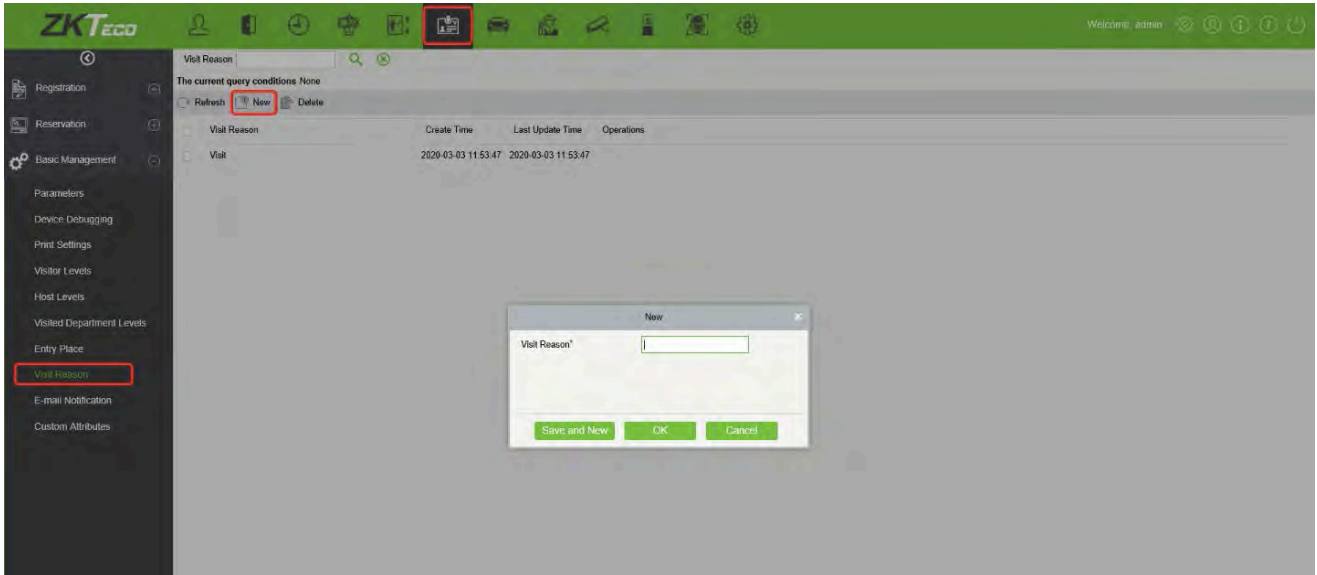

13.2.4 Reservation Audit Settings

Turn on the audit function in **[Visitor Module]→[Basic Management]→[Parameters]**. The visitor reservation will need to be approved before check-in & check-out. If this feature is turned off, the visitor will be able to check-in directly after completing registration on the FaceKiosk self-service device.

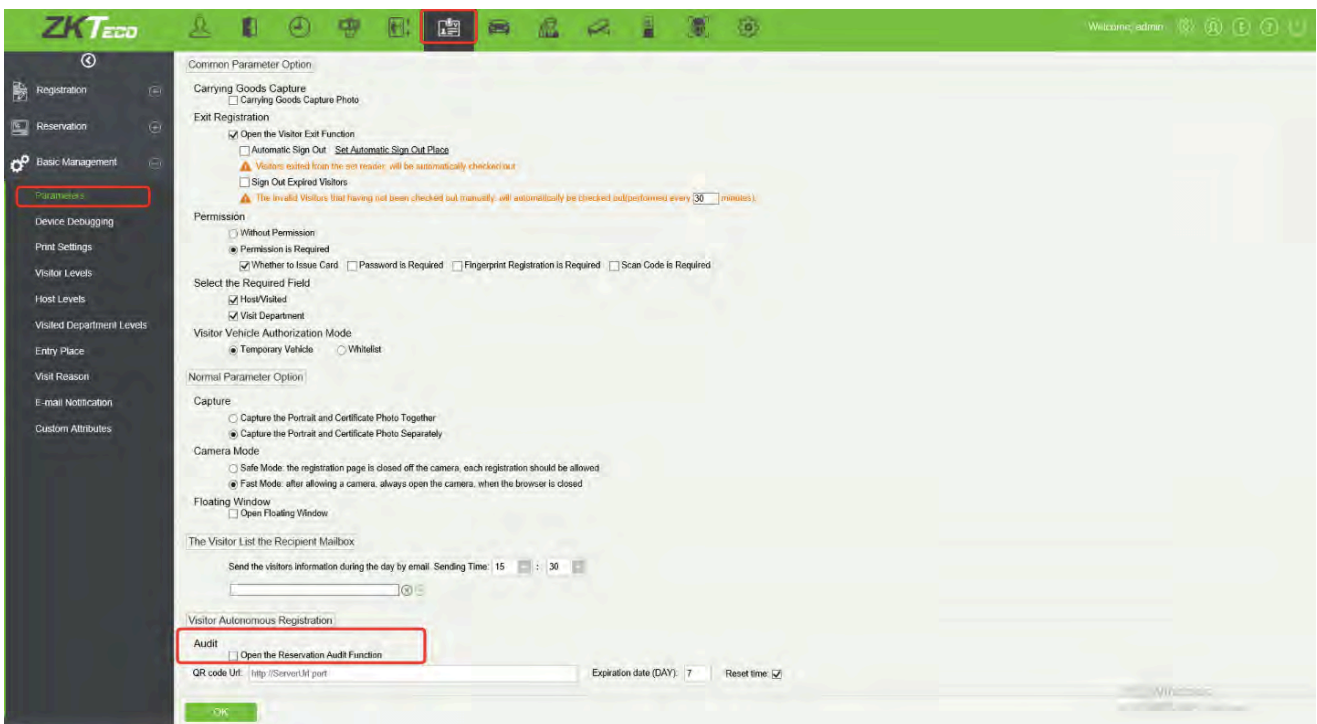

13.2.5 Email Notification Settings

Before using the visitor Email notification function, the user needs to configure the Email Parameter settings in the System settings module of the software.

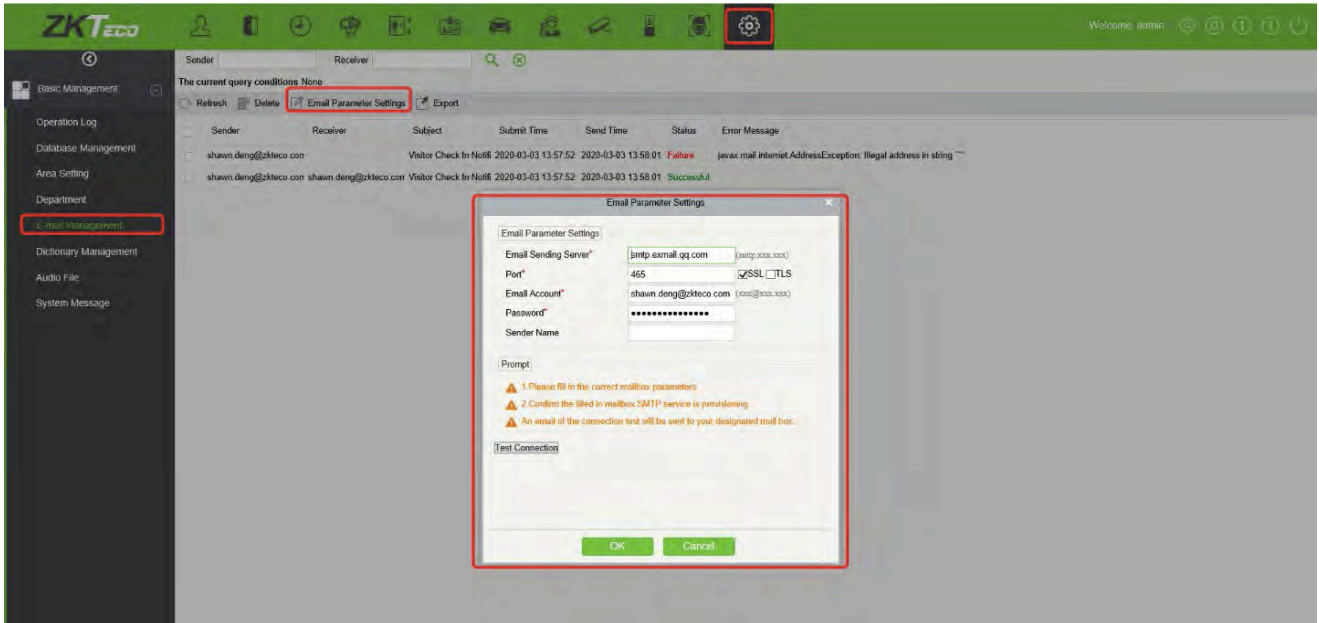

The user can also edit the Email notification template in [Visitor Module]→[Advanced]→[Alert Template].

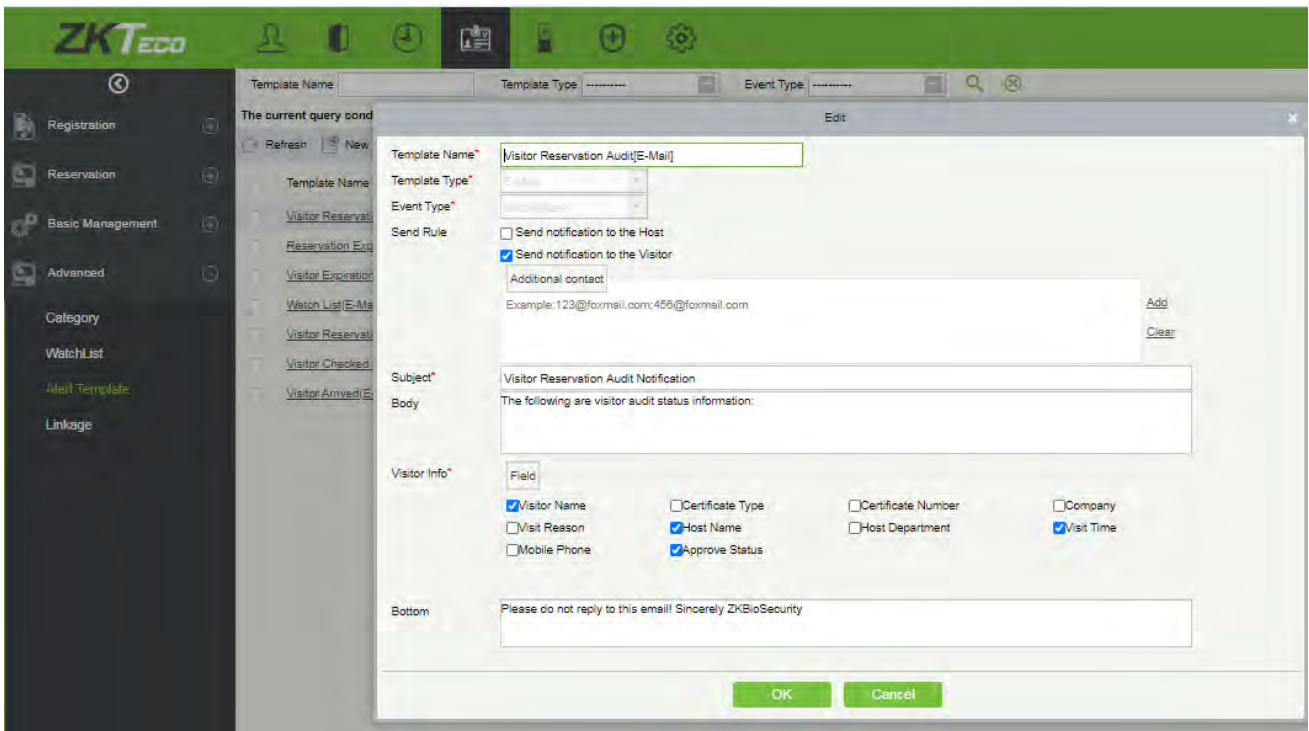

The visitor will receive an email with a QR code after the reservation is approved, which can be used for check-in and check-out on the FaceKiosk self-service visitor device.

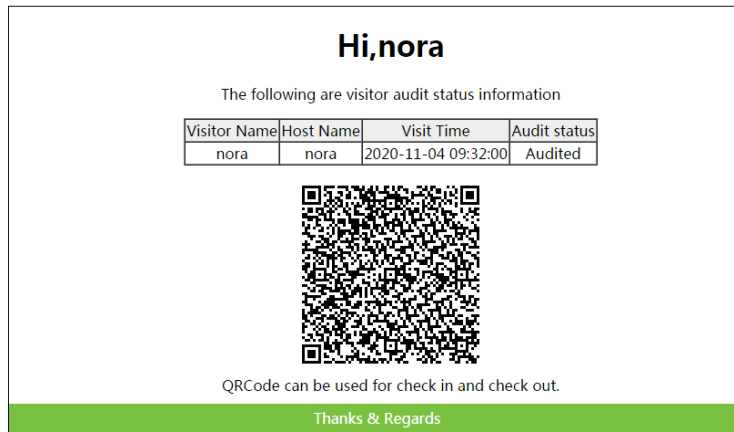

13.2.6 Invitation

The user can send the invitation Email through **[Visitor Module]→[Reservation]→[Invitation]**.

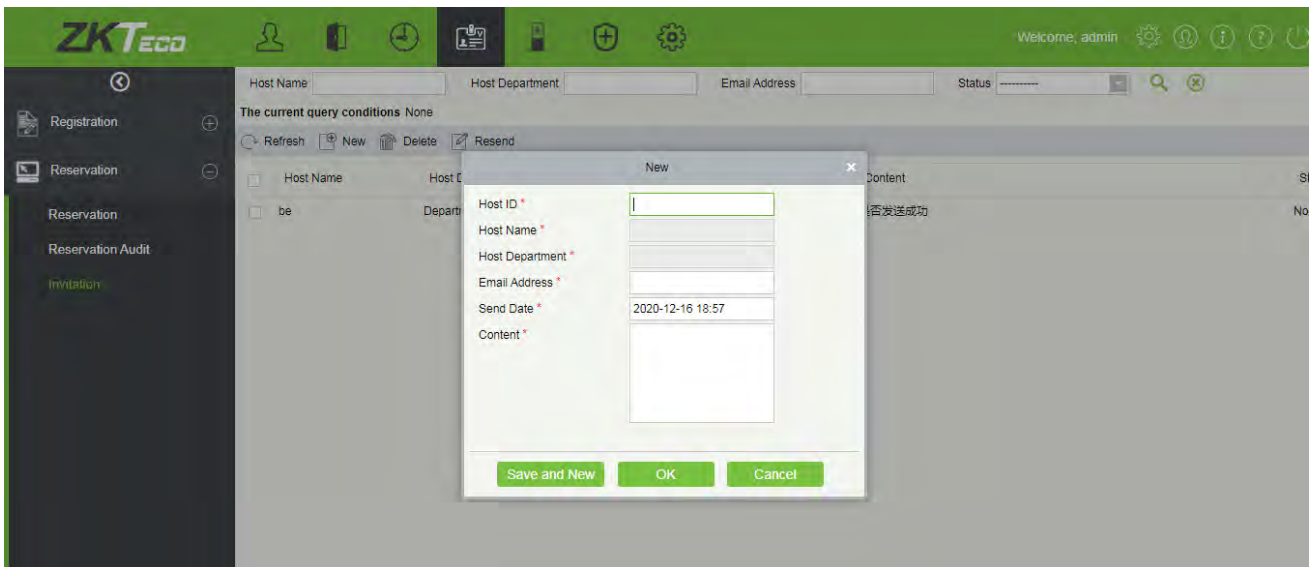

Description of fields:

Host ID: Enter the Host ID.

Host Name: Automatically fills the name of the host.

Host Department: Automatically fills the host's department.

Email Address: Enter the Email address of the guest who needs to be invited.

Send Date: Select the date and time to send the Email.

Content: Enter the invitation content.

13.2.7 Visitor Registration QR Code Settings

In **[Visitor Module]**→**[Basic Management]**→**[Parameters]**, enter the Server Address and Port number to generate the reservation QR code, and set the validity time of the QR code.

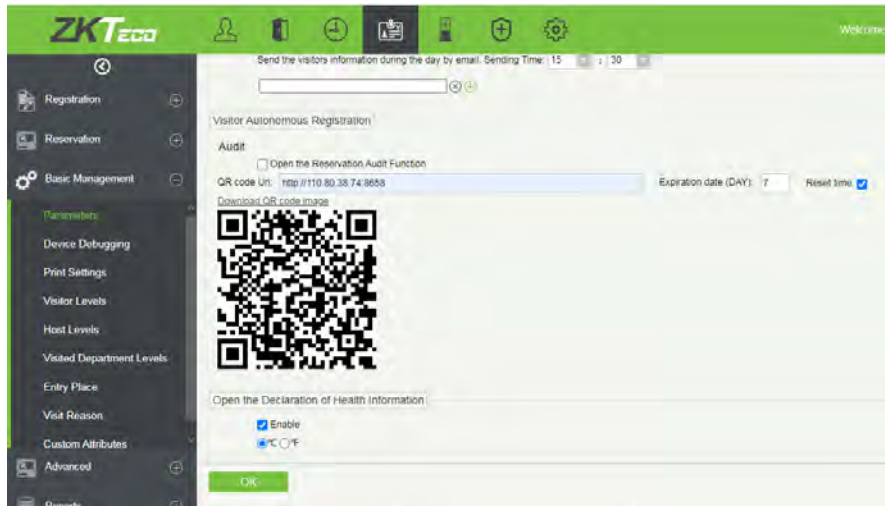

Scan the QR code to open the mobile registration interface. Fill in the required information to complete the registration process as below.

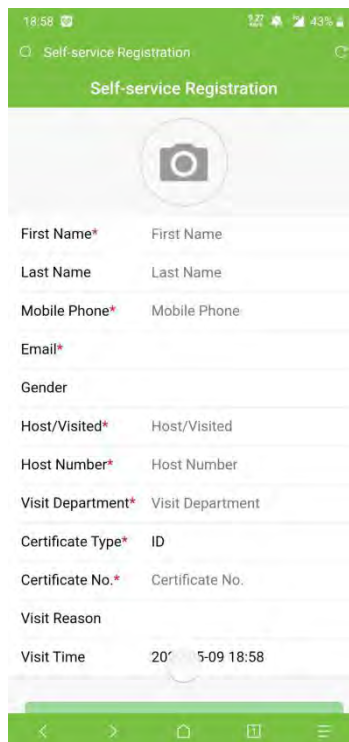

13.2.8 Declaration of Health Information

Open [Visitor Module]→[Basic Management]→[Parameters] to enable the health information declaration function, to register the epidemic prevention information, and enter the temperature of visitors in the mobile visitor registration interface.



ZKTeco Industrial Park, No. 32, Industrial Road,

Tangxia Town, Dongguan, China.

Phone : +86 769 - 82109991

Fax : +86 755 - 89602394

www.zkteco.com

